

**SPLIT TYPE
ROOM AIR CONDITIONER**
Compact Wall Mounted
Wall Mounted / Floor
Compact Cassette / Slim Duct
INVERTER MULTI

SERVICE INSTRUCTION

Models	Indoor unit	Outdoor unit
---------------	--------------------	---------------------

	ASU7RLF1 ASU9RLF1 ASU12RLF1 ASU15RLF1	AOU36RLXFZH AOU45RLXFZ
--	--	---------------------------

	ASU18RLF ASU24RLF AGU9RLF AGU12RLF AGU15RLF	
--	---	--

	AUU7RLF AUU9RLF AUU12RLF AUU18RLF	
--	--	--

	ARU7RLF ARU9RLF ARU12RLF ARU18RLF ARU24RLF	
--	--	--



Refrigerant
R410A

CONTENTS

1. DESCRIPTION OF EACH CONTROL OPERATION

1. CAPACITY CONTROL.....	01-01
2. AUTO CHANGEOVER OPERATION.....	01-01
3. INDOOR FAN CONTROL.....	01-03
4. LOUVER CONTROL.....	01-11
5. OUTDOOR FAN CONTROL.....	01-15
6. COMPRESSOR CONTROL.....	01-15
7. TIMER OPERATION CONTROL.....	01-16
8. ELECTRONIC EXPANSION VALVE CONTROL.....	01-19
9. TEST OPERATION CONTROL.....	01-19
10. PREVENT TO RESTART FOR 3 MINUTES (3 MINUTES ST).....	01-19
11. 4-WAY VALVE EXTENSION SELECT.....	01-19
12. AUTO RESTART.....	01-20
13. MANUAL AUTO OPERATION.....	01-20
14. COMPRESSOR PREHEATING.....	01-21
15. POWERFUL OPERATION (FOR ASU*RLF1 / AGU*RLF type).....	01-21
16. MINIMUM HEAT OPERATION.....	01-21
17. ECONOMY OPERATION.....	01-21
18. HEAT INSULATION CONDITION (BUILDING INSULATION).....	01-22
19. THERMO CONTROL (FOR INDOOR UNIT SENSOR).....	01-22
20. THERMO CONTROL (FOR WIREDE REMOTE SENSOR).....	01-22
21. BASE HEATER OPERATION (FOR AOU36RLXFZH).....	01-23
22. FRESH AIR CONTROL (FOR AU type).....	01-23
23. EXTERNAL ELECTRICAL HEATER CONTROL (FOR AR type).....	01-23
24. DRAIN PUMP OPERATION (For AU / AR type).....	01-24
25. AIR OUTLET SELECTION (DAMPER CONTROL) (FOR AG type).....	01-25
26. DEFROST OPERATION CONTROL.....	01-26
27. CHECK RUN OPERATION (AUTOMATIC WIRING CORRECTION).....	01-28
28. VARIOUS PROTECTIONS.....	01-32
29. PUMP DOWN OPERATION.....	01-34
30. TEST RUN (OUTDOOR UNIT).....	01-35

2. TROUBLE SHOOTING

2-1 ERROR DISPLAY.....	02-01
2-1-1 INDOOR UNIT AND WIRED REMOTE CONTROLLER DISPLAY.....	02-01
2-1-2 SIMPLE REMOTE CONTROLLER DISPLAY.....	02-03
2-1-3 CENTRAL REMOTE CONTROLLER DISPLAY.....	02-03
2-1-4 OUTDOOR UNIT DISPLAY.....	02-03
2-2 TROUBLE SHOOTING WITH ERROR CODE.....	02-05
2-3 TROUBLE SHOOTING WITH NO ERROR CODE.....	02-40
2-4 SERVICE PARTS INFORMATION.....	02-49

***Slim Duct / Compact Cassette
Compact Wall Mounted /
Wall Mounted / Floor type***

INVERTER (MULTI)

**1 . DESCRIPTION OF EACH
CONTROL OPERATION**

1. CAPACITY CONTROL

Compressor frequency decides by capacity of an indoor unit, operation number of an indoor unit, set temperature, room temperature and outside temperature.

2. AUTO CHANGEOVER OPERATION

When the air conditioner is set to the Auto mode by remote controller, operation starts in the optimum mode from among the Heating, Cooling, Dry and Monitoring mode.

During operation, the optimum mode is automatically switched in accordance with temperature changes. The temperature can be set between 64°F(18°C) and 86°F(30°C) in 2°F(1°C) steps.

- ① When operation starts, indoor fan and outdoor fan are operated for around 3 minutes. Room temperature and outdoor temperature are sensed, and the operation mode is selected in accordance with the table below. **<Monitoring mode>**

(Table 1 : Operation mode selection table)

Room temperature (TR)	Operation mode
$TR > Ts + 4^{\circ}\text{F}(+2^{\circ}\text{C})$	Cooling (Automatic dry)
$Ts + 4^{\circ}\text{F}(+2^{\circ}\text{C}) \geq TR \geq Ts - 4^{\circ}\text{F}(-2^{\circ}\text{C})$	*Middle zone
$TR < Ts - 4^{\circ}\text{F}(-2^{\circ}\text{C})$	Heating

TR : Room temperature
Ts : Setting temperature

*If it's Middle zone, operation mode of indoor unit is selected as below.

- (1). Same operation mode is selected as outdoor unit.
If outdoor unit is operating in Cooling, Dry, and Heating mode, indoor unit will be operated by the same operation mode.
- (2). Selected by the outdoor temperature.
If outdoor unit is operating in other than Cooling, Dry, and Heating mode, indoor unit will be operated according to the outdoor temperature as below.

(Fig. 1 : Outdoor temperature zone selection)

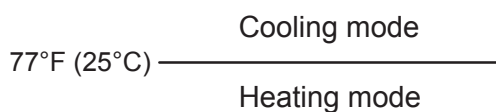

- ② When Heating was selected at ①, the same operation as HEATING OPERATION of page 01-08 is performed.
- ③ When the compressor was stopped for 6 consecutive minutes by the temperature control function after the Cooling(Auto:Dry) or Heating mode was selected at above, operation is switched to Monitoring and the operation mode is selected again.

■ AUTO CHANGEOVER operation flow chart

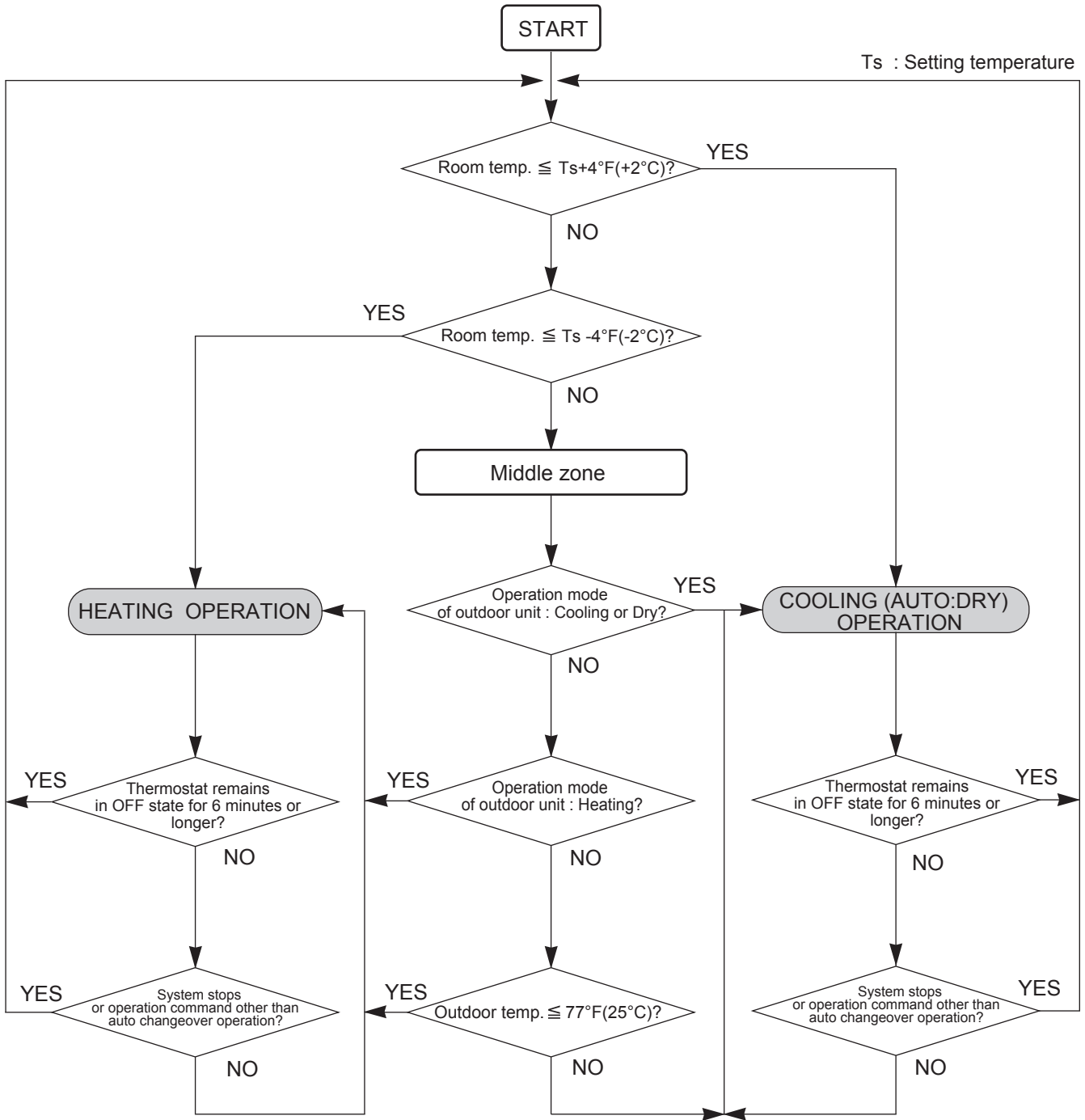

3. INDOOR FAN CONTROL

1. Fan speed

(Table 2 : Indoor fan speed table)

ASU7RLF1 (rpm)

Operation mode	Air flow mode	Fan Speed
Heating	Poweful	1090
	Hi	1050
	Me+	1000
	Me	950
	Lo	850
	Quiet	710
	Cool Air Prevention	600
	S-Lo	480
Cooling / Fan	Poweful	1090
	Hi	1050
	Me	950
	Lo	850
	Quiet	680
	*Soft Quiet	600
	S-Lo	480
	Dry	Auto

ASU9RLF1 (rpm)

Operation mode	Air flow mode	Fan Speed
Heating	Poweful	1140
	Hi	1090
	Me+	1040
	Me	980
	Lo	850
	Quiet	710
	Cool Air Prevention	600
	S-Lo	480
Cooling / Fan	Poweful	1140
	Hi	1090
	Me	980
	Lo	850
	Quiet	680
	*Soft Quiet	600
	S-Lo	480
	Dry	Auto

ASU12RLF1 (rpm)

Operation mode	Air flow mode	Fan Speed
Heating	Poweful	1240
	Hi	1190
	Me+	1120
	Me	1050
	Lo	910
	Quiet	710
	Cool Air Prevention	600
	S-Lo	480
Cooling / Fan	Poweful	1240
	Hi	1190
	Me	1050
	Lo	880
	Quiet	680
	*Soft Quiet	600
	S-Lo	480
	Dry	Auto

ASU15RLF1 (rpm)

Operation mode	Air flow mode	Fan Speed
Heating	Poweful	1320
	Hi	1280
	Me+	1190
	Me	1120
	Lo	1050
	Quiet	770
	Cool Air Prevention	600
	S-Lo	480
Cooling / Fan	Poweful	1320
	Hi	1280
	Me	1090
	Lo	1000
	Quiet	750
	*Soft Quiet	670
	S-Lo	480
	Dry	Auto

*Note, during Economy operation and operation mode is Fan, air flow is 1 step downs.
(Hi > Me, Me > Lo, Quiet > Soft Quiet)

ASU18RLF (rpm)

Operation mode	Air flow mode	Fan Speed
Heating	Hi	1260
	Me+	1120
	Me	1020
	Lo	900
	Quiet	790
	Cool Air Prevention	680
	S-Lo	480
Cooling / Fan	Hi	1260
	Me	1020
	Lo	900
	Quiet	770
	*Soft Quiet	680
	S-Lo	480
Dry	Auto	X, J zone : 770

ASU24RLF (rpm)

Operation mode	Air flow mode	Fan Speed
Heating	Hi	1430
	Me+	1320
	Me	1220
	Lo	1020
	Quiet	900
	Cool Air Prevention	720
	S-Lo	480
Cooling / Fan	Hi	1480
	Me	1220
	Lo	1020
	Quiet	900
	*Soft Quiet	720
	S-Lo	480
Dry	Auto	X, J zone : 900

*Note, during Economy operation and operation mode is Fan, air flow is 1 step downs.
(Hi > Me, Me > Lo, Quiet > Soft Quiet)

AGU9RLF (rpm)

Operation mode	Air flow mode		Speed	
			Upper & Lower air flow mode	Upper air flow mode
Heating	Powerful	(Upper/ Lower)	1230/ 1040	1300
	Hi		1120/ 950	1230
	Me		1000/ 850	1090
	Lo		860/ 730	940
	Quiet		660/ 560	750
	Cool air prevention		660/ 560	680
	S-Lo		660/ 560	680
Cooling/ Fan	Powerful	(Upper/ Lower)	1230/ 1040	1300
	Hi		1120/ 950	1230
	Me		960/ 820	1070
	Lo		820/ 700	910
	Quiet		660/ 560	750
	*Soft Quiet		570/ 480	680
	S-Lo		660/ 560	680
Dry	Auto	(Upper/ Lower)	---- / ----	X, J zone : 750

AGU12RLF (rpm)

Operation mode	Air flow mode		Speed	
			Upper & Lower air flow mode	Upper air flow mode
Heating	Powerful	(Upper/ Lower)	1350/ 1150	1370
	Hi		1240/ 1040	1300
	Me		1080/ 920	1140
	Lo		910/ 770	980
	Quiet		660/ 560	750
	Cool air prevention		660/ 560	680
	S-Lo		660/ 560	680
Cooling/ Fan	Powerful	(Upper/ Lower)	1350/ 1150	1370
	Hi		1240/ 1040	1300
	Me		1050/ 890	1120
	Lo		860/ 730	930
	Quiet		660/ 560	750
	*Soft Quiet		570/ 480	680
	S-Lo		660/ 560	680
Dry	Auto	(Upper/ Lower)	---- / ----	X, J zone : 750

AGU15RLF (rpm)

Operation mode	Air flow mode		Speed	
			Upper & Lower air flow mode	Upper air flow mode
Heating	Powerful	(Upper/ Lower)	1440/ 1230	1440
	Hi		1330/ 1120	1370
	Me		1140/ 970	1180
	Lo		940/ 800	1020
	Quiet		660/ 560	750
	Cool air prevention		660/ 560	680
	S-Lo		660/ 560	680
Cooling/ Fan	Powerful	(Upper/ Lower)	1440/ 1230	1440
	Hi		1330/ 1120	1370
	Me		1100/ 930	1160
	Lo		890/ 750	960
	Quiet		660/ 560	750
	*Soft Quiet		570/ 480	680
	S-Lo		660/ 560	680
Dry	Auto	(Upper/ Lower)	---- / ----	X, J zone : 750

*Note, during Economy operation and operation mode is Fan, air flow is 1 step downs.
(Hi > Me, Me > Lo, Quiet > Soft Quiet)

AUU7RLF (rpm)

Operation mode	Air flow mode	Fan Speed
Heating	Hi	590
	Me+	570
	Me	540
	Lo	490
	Quiet	440
	Cool Air Prevention	400
	S-Lo	300
Cooling / Fan	Hi	590
	Me	540
	Lo	490
	Quiet	440
	*Soft Quiet	400
	S-Lo	300
Dry	Auto	X, J zone : 440

AUU9RLF (rpm)

Operation mode	Air flow mode	Fan Speed
Heating	Hi	590
	Me+	570
	Me	540
	Lo	490
	Quiet	440
	Cool Air Prevention	400
	S-Lo	300
Cooling / Fan	Hi	590
	Me	540
	Lo	490
	Quiet	440
	*Soft Quiet	400
	S-Lo	300
Dry	Auto	X, J zone : 440

AUU12RLF (rpm)

Operation mode	Air flow mode	Fan Speed
Heating	Hi	650
	Me+	620
	Me	580
	Lo	520
	Quiet	460
	Cool Air Prevention	400
	S-Lo	300
Cooling / Fan	Hi	660
	Me	580
	Lo	520
	Quiet	460
	*Soft Quiet	400
	S-Lo	300
Dry	Auto	X, J zone : 460

AUU18RLF (rpm)

Operation mode	Air flow mode	Fan Speed
Heating	Hi	840
	Me+	800
	Me	750
	Lo	650
	Quiet	500
	Cool Air Prevention	400
	S-Lo	300
Cooling / Fan	Hi	790
	Me	660
	Lo	570
	Quiet	460
	*Soft Quiet	400
	S-Lo	300
Dry	Auto	X, J zone : 460

*Note, during Economy operation and operation mode is Fan, air flow is 1 step downs.
(Hi > Me, Me > Lo, Quiet > Soft Quiet)

ARU7RLF (Static pressure:25Pa) (rpm)

Operation mode	Air flow mode	Fan Speed
Heating	Hi	1160
	Me	1000
	Lo	940
	Quiet	880
	S-Lo	500
Cooling / Fan	Hi	1160
	Me	1000
	Lo	940
	Quiet	880
	*Soft Quiet	500
	S-Lo	500
Dry	Auto	X, J zone : 880

ARU9RLF (Static pressure:25Pa) (rpm)

Operation mode	Air flow mode	Fan Speed
Heating	Hi	1260
	Me	1160
	Lo	1060
	Quiet	960
	S-Lo	500
Cooling / Fan	Hi	1260
	Me	1160
	Lo	1060
	Quiet	960
	*Soft Quiet	500
	S-Lo	500
Dry	Auto	X, J zone : 960

ARU12RLF (Static pressure:25Pa) (rpm)

Operation mode	Air flow mode	Fan Speed
Heating	Hi	1340
	Me	1240
	Lo	1140
	Quiet	1030
	S-Lo	500
Cooling / Fan	Hi	1340
	Me	1240
	Lo	1140
	Quiet	1030
	*Soft Quiet	500
	S-Lo	500
Dry	Auto	X, J zone :1030

ARU18RLF (Static pressure:25Pa) (rpm)

Operation mode	Air flow mode	Fan Speed
Heating	Hi	1380
	Me	1300
	Lo	1220
	Quiet	1140
	S-Lo	600
Cooling / Fan	Hi	1380
	Me	1300
	Lo	1220
	Quiet	1140
	*Soft Quiet	600
	S-Lo	600
Dry	Auto	X, J zone :1140

ARU24RLF (Static pressure:25Pa) (rpm)

Operation mode	Air flow mode	Fan Speed
Heating	Hi	1460
	Me	1360
	Lo	1260
	Quiet	1180
	S-Lo	600
Cooling / Fan	Hi	1460
	Me	1360
	Lo	1260
	Quiet	1180
	*Soft Quiet	600
	S-Lo	600
Dry	Auto	X, J zone :1180

*Note, during Economy operation and operation mode is Fan, air flow is 1 step downs.
(Hi > Me, Me > Lo, Quiet > Soft Quiet)

2. FAN OPERATION

The airflow can be switched in 5 steps such as Auto, Quiet, Lo, Me, Hi, while the indoor fan only runs.

When Fan mode is set at (Auto), it operates on (Me) Fan Speed. < All models >

3. COOLING OPERATION (Auto : Cooling)

Switch the airflow [Auto], and the indoor fan will run according to a room temperature, as shown in Fig. 2 .

On the other hand, if switched in [Hi]~[Quiet], the indoor fan will run at a constant airflow of [Cooling] operation modes Quiet, Lo, Me, Hi.

(Fig. 2 : Airflow change - over)

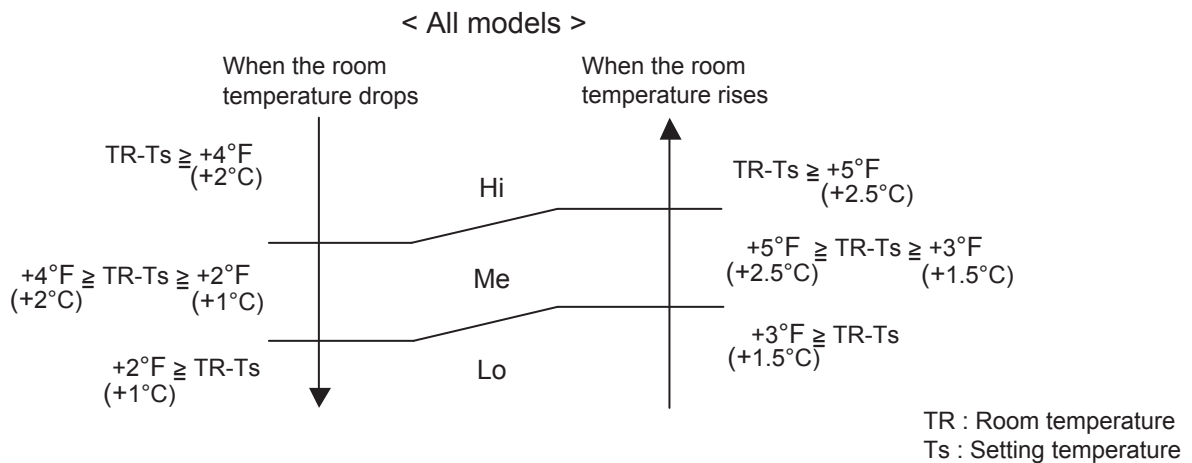

4. DRY OPERATION (Auto : Dry)

During the dry operation, the fan speed setting can not be changed, it operates automatically as shown in Fig. 3 .

Room temperature variation which the room temperature sensor of the indoor unit body has detected.

(Fig. 3 : Indoor fan control)

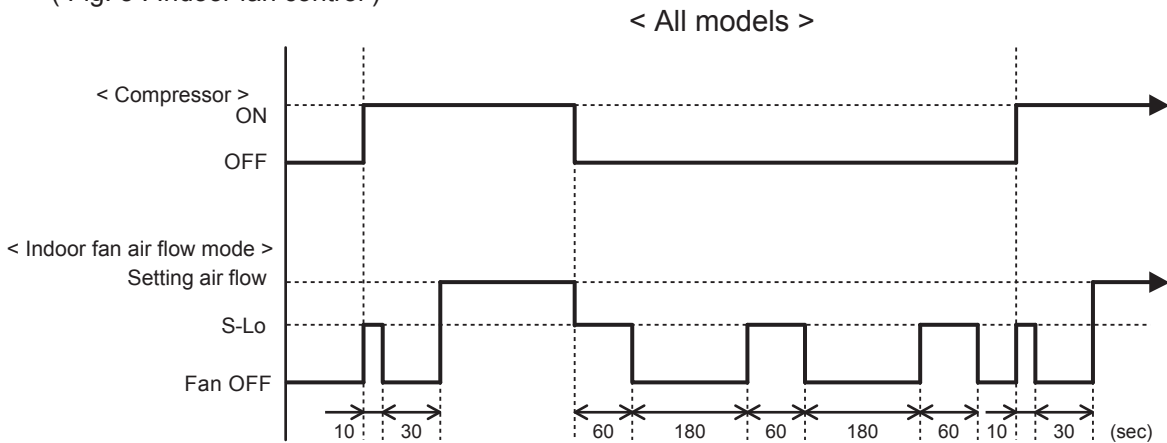

5. HEATING OPERATION (Auto : Heating)

Switch the airflow [Auto], and the indoor fan will run according to a room temperature, as shown in Fig. 4 .

On the other hand, if switched in [Hi] ~ [Quiet], the indoor fan will run at a constant airflow of [Heat] operation modes Quiet, Lo, Me, Hi, as shown in Table 2 .

(Fig. 4 : Airflow change - over)

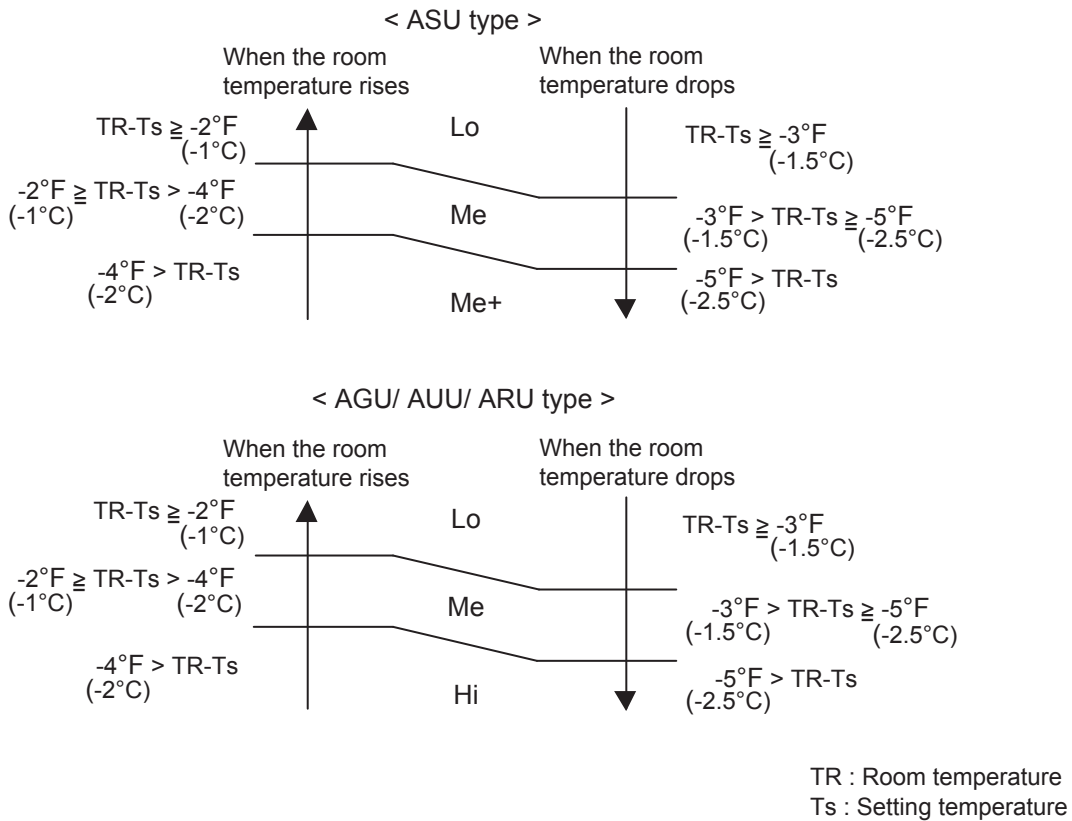

6. COOL AIR PREVENTION CONTROL (For Heating and Minimum Heat operation)

The maximum value of the indoor fan speed is set as shown in Fig. 5 , based on the detected temperature by the indoor heat exchanger sensor in heating mode.

Field setting is necessary at AU and AR type as "Cool air prevention : effective"

(Fig. 5 : Airflow change - over for cool air prevention)

During NORMAL HEATING OPERATION

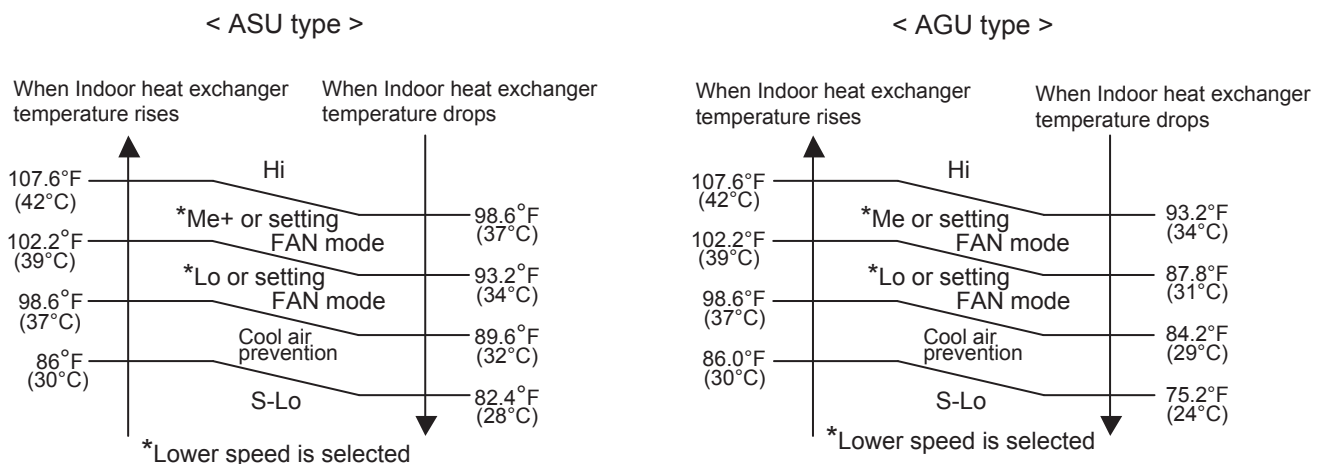

< AUU type >

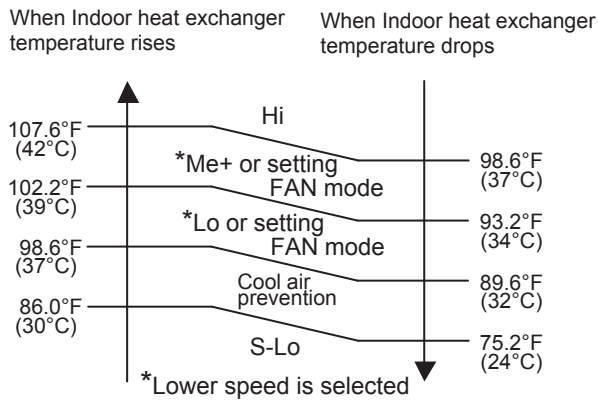

< ARU type >

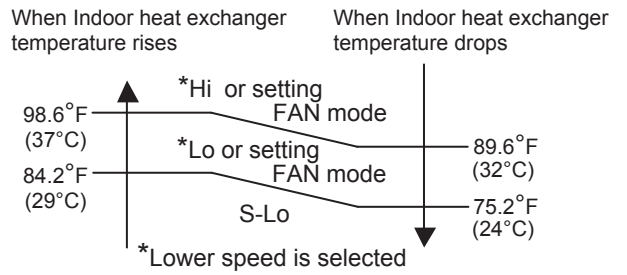

During MINIMUM HEAT OPERATION

< ASU / AUU type >

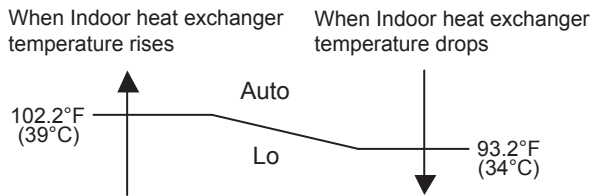

< AGU type >

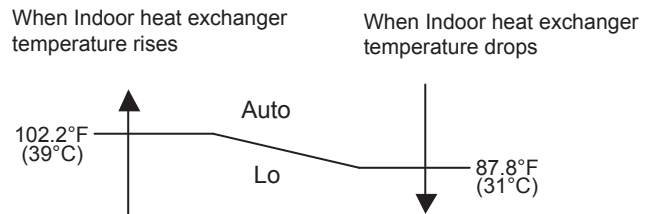

< ARU type >

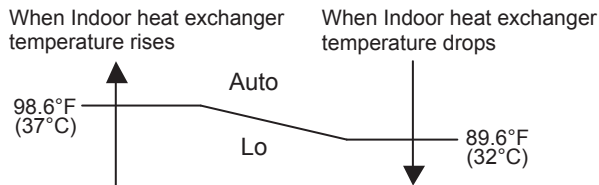

4. LOUVER CONTROL

For Compact Wall Mounted Type < ASU7/ 9/ 12/ 15RLF1 >

1. VERTICAL LOUVER CONTROL

(Function Range)

Each time the button is pressed, the air direction range will change as follow:

(Fig. 6 : Vertical air direction range)

① ↔ ② ↔ ③ ↔ ④ ↔ ⑤ ↔ ⑥ ↔ ⑦

The Remote Controller's display does not change.

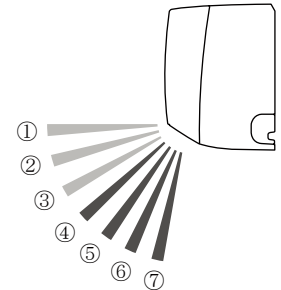

- If you set the angle to position ④~⑦ for more than 30 minutes in COOL or DRY mode, they automatically return to position ③ .
In COOL or DRY mode, if the angle is set to position ④~⑦ for many hours, condensation may be formed, and the drips may wet your property.
- Use the air direction adjustments within the ranges shown above.
- The vertical airflow direction is set automatically as shown, in accordance with the type of operation selected.
 - Cooling / Dry mode : Horizontal flow ①
 - Heating mode : Downward flow ⑦
- During AUTO or Heating mode operation, for the first a few minutes after beginning operation, air-flow will be horizontal ① ; the air direction cannot be adjusted during this period.
The air flow direction setting will temporarily become ① when the temperature of the air -flow is low at the start of the Heating mode.

2. SWING OPERATION

To select Vertical Airflow Swing Operation

When the swing signal is received from the remote controller, the vertical louver starts to swing.

(Table 3 : Swinging range)

The type of operation	Range
Cooling / Dry mode Fan mode (①~③)	① ↔ ③
Heating mode Fan mode (④~⑦)	④ ↔ ⑦

- The SWING operation may stop temporarily when the air conditioner's fan is not operating, or when operating at very low speeds.

To select Horizontal Airflow Swing Operation

(No function)

For Wall Mounted Type < ASU18/ 24RLF >

1. VERTICAL LOUVER CONTROL

(Function Range)

Each time the button is pressed, the air direction range will change as follow :

① ↔ ② ↔ ③ ↔ ④ ↔ ⑤ ↔ ⑥

- Use the air direction adjustments within the ranges shown above.
- The vertical airflow direction is set automatically as shown, in accordance with the type of operation selected.

Cooling / Dry mode : Horizontal flow ①

Heating mode : Downward flow ⑤

- When the temperature of the air being blown out is low at the start of heating operation or during defrosting, the airflow direction temporarily becomes ① to prevent cold air being blown onto the body.
- During use of the Cooling and Dry modes, do not set the Air Flow Direction Louver in the Heating range (④~⑥) for long period of time, since water vapor may condense near the outlet louvers and drop of water may drip from the air conditioner. During the Cooling and Dry modes, if the Air Flow Direction Louvers are left in the heating range for around 20 minutes, they will automatically return to position ③.

(Fig. 7 : Vertical air direction range)

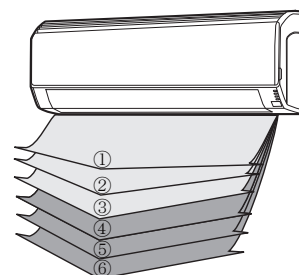

2. HORIZONTAL LOUVER CONTROL

(Function Range)

Each time the button is pressed, the air direction range will change as follow :

① ↔ ② ↔ ③ ↔ ④ ↔ ⑤

(Fig. 8 : Horizontal air direction range)



Horizontal Louver

3. SWING OPERATION

Vertical Airflow Swing Operation

When the swing signal is received from the remote controller, the vertical louver starts to swing.

(Table 4 : Swinging range)

The type of operation	Range
Cooling / Dry / Fan mode (①~③)	① ↔ ④
Heating / Fan mode (④~⑦)	③ ↔ ⑥

- When the indoor fan is S-Lo or Stop mode, the swing operation is interrupted and it stops at either upper end or bottom end.

Horizontal Airflow Swing Operation

When the swing signal is received from the remote controller, the horizontal louver starts to swing.

(Table 5 : Swinging range)

The type of operation	Range
Cooling / Dry / Heating / Fan mode	① ↔ ⑤

- When the indoor fan is S-Lo or Stop mode, the swing operation is interrupted and it stops at either upper end or bottom end.

Vertical and Horizontal Airflow Swing Operation

- When the horizontal swing signal is input from remote control, the combination of the vertical and horizontal swing operation is performed.

※ **Power Diffuser doesn't swing in any swing operation.**

For Floor Type < AGU9/ 12/ 15RLF >

1. VERTICAL LOUVER CONTROL

(Function Range)

Each time the button is pressed, the air direction range will change as follow : (Fig. 9 : Air direction range)

① ⇄ ② ⇄ ③ ⇄ ④ ⇄ ⑤

- The Remote Controller's display does not change.
- Use the air direction adjustments within the ranges shown above.
- The vertical airflow direction is set automatically as shown, in accordance with the type of operation selected.

Cooling / Dry / Fan mode : Horizontal flow ①
 Heating mode : Downward flow ④

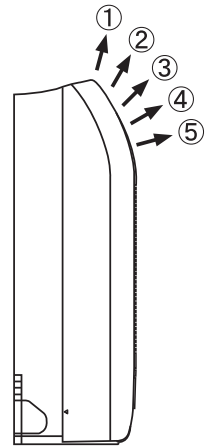

- When the temperature of the air being blown out is low at the start of heating operation or during defrosting, the airflow direction temporarily becomes ① to prevent cold air being blown onto the body.
- During Monitor operation in AUTO CHANGEOVER mode, the airflow direction automatically becomes ①, and it cannot be adjusted.

2. ADJUST THE RIGHT-LEFT LOUVERS

- Move the Right-Left louvers to adjust airflow in the direction you prefer.

(Fig. 10 : Air direction range)

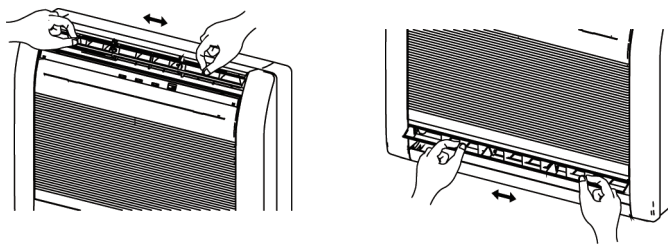

3. SWING OPERATION

To select Vertical Airflow Swing Operation

When the swing signal is received from the remote controller, the vertical louver starts to swing .

(Table 6 : Swinging range)

The type of operation	Range
Cooling / Dry / Heating / Fan mode	① ⇄ ⑤

- When the indoor fan is either at S-Lo or Stop mode, the swinging operation is interrupted and it stops at either upper end or bottom end.

To select Horizontal Airflow Swing Operation

(No function)

For Compact Cassette Type < AUU7/ 9/ 12/ 18RLF >

1. VERTICAL LOUVER CONTROL

(Function Range)

Each time the button is pressed, the air direction range will change as follow :

① ↔ ② ↔ ③ ↔ ④

(Fig. 11 : Vertical air direction range)

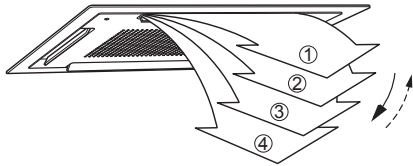

- Use the air direction adjustments within the ranges shown above.
- The vertical airflow direction is set automatically as shown, in accordance with the type of operation selected.

Cooling / Dry / Fan mode : Horizontal flow ①
 Heating mode : Downward flow ④

- During AUTO mode operation, for the first minute after start-up, air-flow will be horizontal ① ; the air direction cannot be adjusted during this period.

2. SWING OPERATION

When the swing signal is received from the remote controller, the vertical louver starts to swing. The range of swing depends on the set airflow direction.

(Table 7 : Swinging range)

The type of operation	Range
Cooling / Dry / Heating / Fan mode	① ↔ ④

- When the indoor fan is either at S-Lo or Stop mode, the swinging operation is interrupted and the louver stops at the memorized position.
 (Stop mode means Operation stop.)

5. OUTDOOR FAN CONTROL

1. Outdoor Fan Motor

The Table 5 shows the fan speed of the outdoor unit.

(Table 8 : Fan speed of the outdoor unit)

	Cooling	Heating
AOU36RLXFZH AOU45RLXFZ	890/ 830/ 710/ 640/ 580/ 520/ 460/ 390/ 340/ 290 rpm	910/ 830/ 710/ 640/ 580/ 520/ 460/ 390/ 340/ 290 rpm

6. COMPRESSOR CONTROL

1. OPERATION FREQUENCY RANGE

The operation frequency of the compressor is different based on the operation mode as shown in the Table 9 .

(Table 9 : Compressor operation frequency range)

	Cooling		Heating	
	Min	Max	Min	Max
AOU36RLXFZH	20	80	20	120
AOU45RLXFZ	20	100	20	110

2. OPERATION FREQUENCY CONTROL AT START UP

The compressor frequency soon after the start-up is controlled as shown in the Fig. 12 .

(Fig. 12 : Compressor control at Start-up)

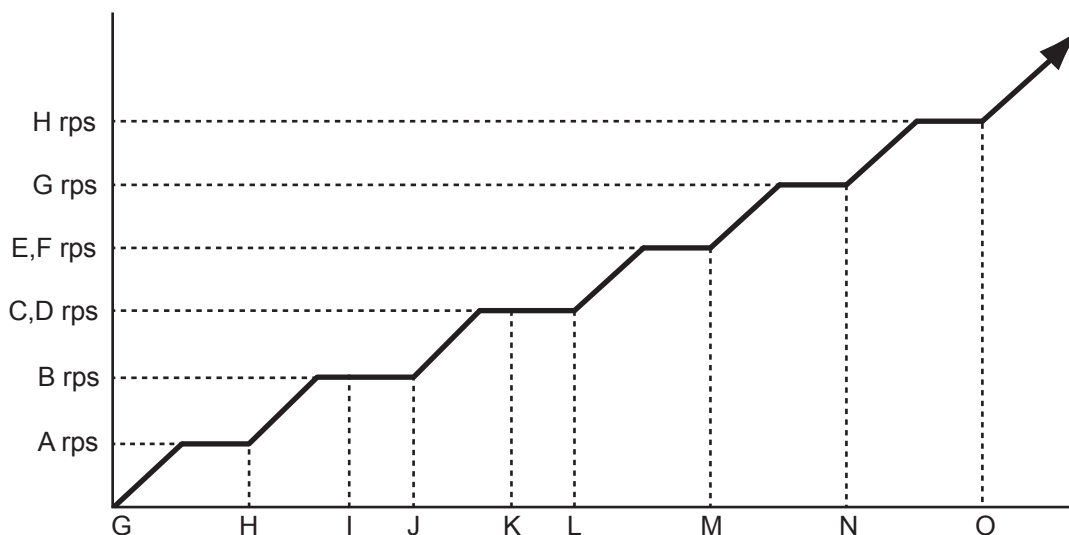

[Frequency]

	A rps	B rps	C rps	D rps	E rps	F rps	G rps	H rps
AOU36RLXFZH AOU45RLXFZ	30	36	47	47	60	60	80	100

[Time]

	G ~ H	H ~ I	I ~ J	J ~ K	K ~ L	L ~ M	M ~ N	N ~ O
AOU36RLXFZH AOU45RLXFZ	60sec	60sec	480sec	120sec	300sec	180sec	120sec	120sec

7. TIMER OPEARTION CONTROL

7-1 WIRELESS REMOTE CONTROLLER

The Table 10 shows the available timer setting based on the product model.

(Table 10 : Timer setting)

ON TIMER / OFF TIMER	PROGRAM TIMER	SLEEP TIMER
○	○	○

1. ON / OFF TIMER

- OFF timer : When the clock reaches the set time, the air conditioner will be turned off.

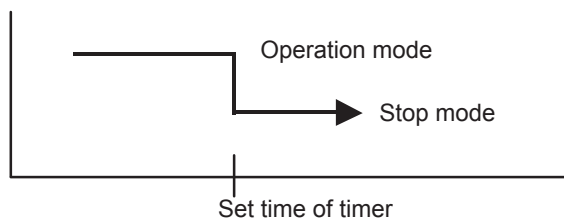

- ON timer : When the clock reaches the set time, the air conditioner will be turned on.

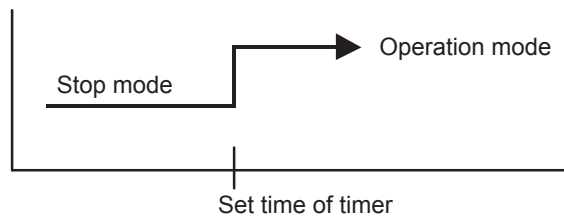

2. PROGRAM TIMER

- The program timer allows the OFF timer and ON timer to be used in combination one time.

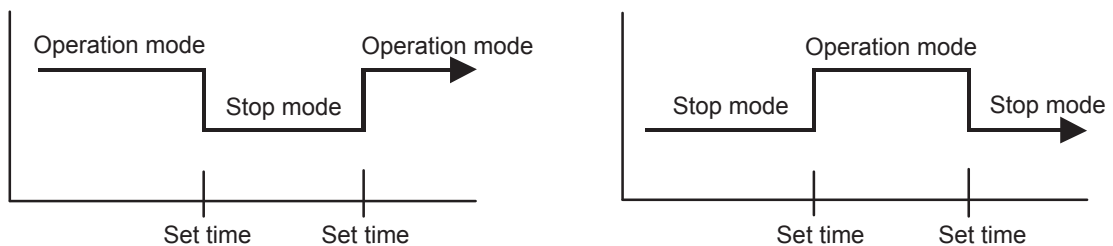

- Operation will start from the timer setting (either OFF timer or ON timer) whichever is closest to the clock's current timer setting.
The order of operations is indicated by the arrow in the remote control unit's display.
- SLEEP timer operation cannot be combined with ON timer operation.

3. SLEEP TIMER

If the sleep is set, the room temperature is monitored and the operation is stopped automatically. If the operation mode or the set temperature is change after the sleep timer is set, the operation is continued according to the changed setting of the sleep timer from that time ON.

In the cooling operation mode

When the sleep timer is set, the setting temperature is increased 2°F(1°C). It increases the setting temperature another 2°F(1°C) after 1 hour. After that, the setting temperature is not changed and the operation is stopped at the time of timer setting.

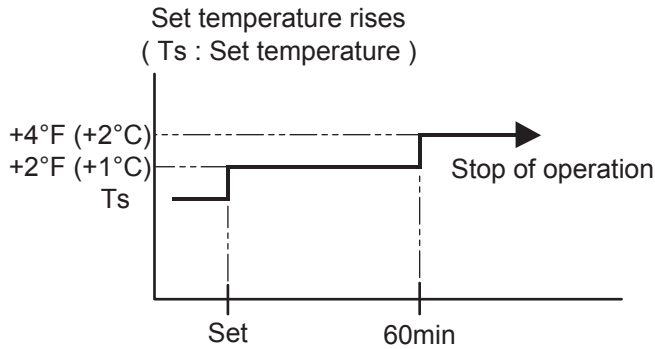

In the heating operation mode

When the sleep timer is set, the setting temperature is decreased 2°F(1°C). It decreases the setting temperature another 2°F(1°C) every 30 minutes. Upon lowering 8°F(4°C), the setting temperature is not changed and the operation stops at the time of timer setting.

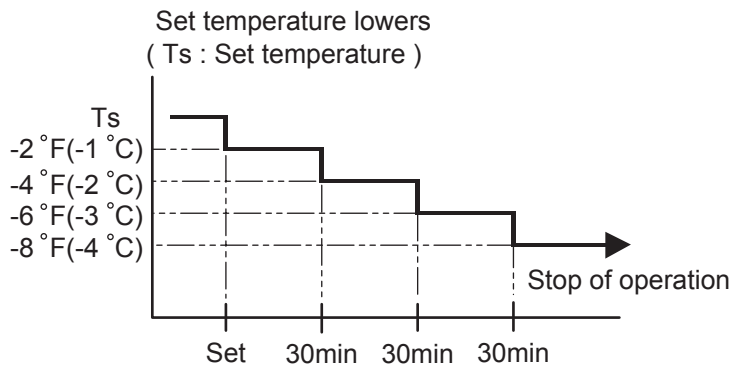

7-2 WIRED REMOTE CONTROLLER

The Table 11 shows the available timer setting based on the product model.

(Table 11 : Timer setting)

ON TIMER / OFF TIMER	WEEKLY TIMER	TEMPERATURE SET BACK TIMER
○	○	○

1. ON TIMER / OFF TIMER

Same to 6-1 **ON / OFF TIMER** and shown in those.

2. WEEKLY TIMER

This timer function can set operation times of the each day of the week.

All days can be set together, the weekly timer can be used to repeat the timer setting for all of the days.

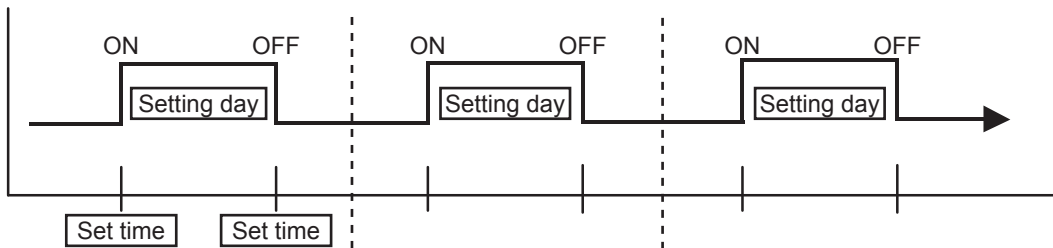

3. TEMPERATURE SET BACK TIMER

This timer function can change setting temperature of setting operation times of the each day of the week. This can be together with other timer setting.

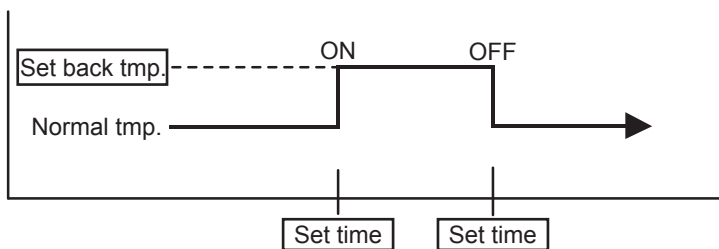

8. ELECTRONIC EXPANSION VALVE CONTROL

The most proper opening of the electronic expansion valve is calculated and controlled under the present operating condition based on the Table 13 .

The compressor frequency, the temperatures detected by the discharge temperature sensor and the outdoor temperature sensor.

(Table 12 : The pulse range of the electronic expansion valve control)

	Operation mode	Pulse range
AOU36RLXFZH	Cooling /Dry mode	50 ~ 480
AOU45RLXFZ	Heating mode	30 ~ 480

* At the time of supplying the power to the outdoor unit, the initialization of the electronic expansion valve is operated (825 pulses are input to the closing direction).

9. TEST OPERATION CONTROL

▪ With Wireless Remote Controller (with TEST RUN button)

Under the condition where the air conditioner runs, press the TEST RUN button, and the test operation control mode will appear.

During test running, the operation lamp and timer lamp of the air conditioner body twinkle simultaneously. Set the test operation mode, and the compressor will continue to run regardless of whether the room temperature sensor detects.

The test operation mode is released if 60 minutes have passed after setting up the test operation.

▪ With Wireless Remote Controller (without TEST RUN button)

Under the condition where the air conditioner runs, press the MANUAL AUTO button of the indoor unit for more than 10 seconds.

During test running, the operation lamp and timer lamp of the air conditioner body twinkle simultaneously. Set the test operation mode, and the compressor will continue to run regardless of whether the room temperature sensor detects.

The test operation mode is released, if 60 minutes have passed after setting up the test operation or pressing the MANUAL AUTO button of the indoor unit for more than 3 seconds.

▪ With Wired Remote Controller (without TEST RUN button)

Under the condition where the air conditioner stops, press the MASTER CONTROL button and the FAN CONTROL button simultaneously for 5 seconds or more, and the test operation control mode will appear.

During test running, " a f " will display on the remote controller display.

Set the test operation mode, and the compressor will continue to run regardless of whatever the room temperature sensor detects.

The test operation mode is released if 60 minutes have passed after setting up the test operation.

▪ Outdoor unit TEST RAN operation

It can carry out test run from the outdoor unit (Refer to 30.TEST RUN (For Outdoor unit))

10. PREVENT TO RESTART FOR 3 MINUTES (3 MINUTES ST)

The compressor won't enter operation status for 3 minutes after the compressor is stopped, even if any operation is given.

11. 4-WAY VALVE EXTENSION SELECT

At the time when the air conditioner is switched from the Cooling mode to Heating mode, the compressor is stopped, and the 4-way valve is switched in 3 minutes later after the compressor stopped.

12. AUTO RESTART

When the power was interrupted by a power failure, etc. during operation, the operation contents at that time are memorized and when power is recovered, operation is automatically resumed with the memorized operation contents.

(Table 13 : Operation contents memorized when the power is interrupted)

	Wireless remote controller	Wired remote controller (When Memory Backup : Disable)	Wired remote controller (When Memory Backup : Enable)	
Operation mode	○	○	○	
Set temperature	○	○	○	
Set air flow	○	○	○	
Thermistor detected position	—	×	○	
Timer mode	○	×	OFF Timer	×
			ON Timer	×
			WEEKLY Timer	○
			TEMPERRATURE SET BACK Timer	○

○ : Memorize
 × : Not memorize

*It is necessary to set on the DIP-SW1-No,6 of the wired remote controller, to enable the memory backup.
 Refer to the installation manual of wired remote controller for details.

13. MANUAL AUTO OPERATION

If MANUAL / AUTO Button is pushed continuous from 3 seconds to 10 seconds,
 manual auto operation will starts.

If the remote control is lost or battery power dissipated, this function will work without the remote control.

(Table 14 : Manual auto operation control)

Functions	All models
OPERATION MODE	Auto changeover
SETTING TEMP.	76°F(24°C)
FAN MODE	Auto
VERTICAL LOUVER	NORMAL
HORIZONTAL LOUVER	NORMAL
TIMER MODE	Continuous (No timer setting available)
SWING OPERATION	OFF
ECONOMY	OFF

14. COMPRESSOR PREHEATING

When the outdoor temperature is lower than 28.4°F(-2°C) and the all operation mode has been stopped for 30 minutes, power is applied to the compressor and the compressor is heated.

(By heating the compressor, warm air is quickly discharged when operation is started.)

When operation was started and when the outdoor temperature rises to 25°C or greater, preheating is ended.

(Fig.13 : Compressor preheating)

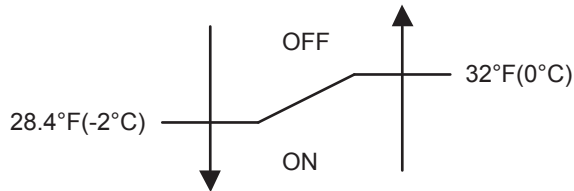

15. POWERFUL OPERATION (For ASU*RLF1/ AGU*RLF type)

The POWERFUL OPERATION functions by pressing POWERFUL button on the remote controller. The indoor unit & outdoor unit will operate at maximum power as shown in Table 15 .

(Table 15 : Powerful operation)

COMPRESSOR FREQUENCY	Maximum
FAN CONT. MODE	Powerful
SETTING LOUVER	Cooling/ Dry : 3, Heating : 6 for ASU*RLF1
	Cooling/ Dry : 4, Heating : 5 for AGU*RLF

Release Condition is as follows.

[Cooling / Dry]

- Room temperature \leq Setting temperature -3.0°F(- 1.5°C) or Operation time has passed 20 minutes.

[Heating]

- Room temperature \geq Setting temperature +3.0°F(+1.5°C) or Operation time has passed 20 minutes.

16. MINIMUM HEAT OPERATION

MINIMUM HEAT operation performs as below when pressing MIN. HEAT button or Weekly timer setting on the remote controller.

(Table 16 : Minimum heat operation)

Mode	Heating
Settingtemperature	50°F(10°C)
Fanmode	Auto
LEDdisplay	Economy
Defrost operation	Operate as normal

17. ECONOMY OPERATION

The ECONOMY operation functions by pressing ECONOMY button on the remote controller.

At the maximum output, ECONOMY Operation is approximately 70% of normal air conditioner operation for cooling and heating.

The ECONOMY operation is almost the same operation as below settings.

(Table 17 : Economy operation)

Mode	Cooling/ Dry	Heating
Target temperature	Setting temp.+2°F(+1°C)	Setting temp.-2°F(-1°C)

18. HEAT INSULATION CONDITION (BUILDING INSULATION)

This setting can make the room temperature control more suitable for homes or buildings with high insulation (Function Number 95).

When the thermo sensor is turned ON it controls the compressor frequency at initial start to prevent overshoot in heating or cooling.

19. THERMO CONTROL (FOR INDOOR UNIT SENSOR)

When room temperature is controlled by the Indoor unit sensor, compressor operation is as shown in Fig. 14 and 15.

But, adjustment is possible by the room temperature correction function setting.
(Function Number 30 or 31)

(Fig. 14 : For Cooling operation)

(Fig. 15 : For Heating operation)

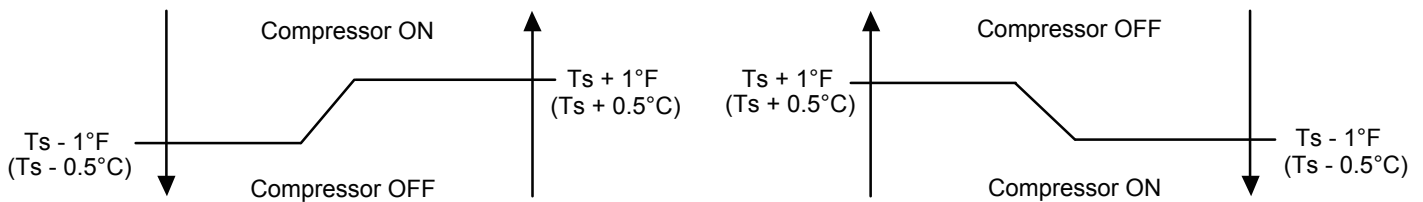

• T_s : Setting temperature

20. THERMO CONTROL (FOR WIRED REMOTE SENSOR)

When room temperature is controlled by the Wired remote sensor, compressor operation is as shown in Fig. 16 and 17.

But, adjustment is possible by the room temperature correction function setting.
(Function Number 92 or 93)

(Fig. 16 : For Cooling operation)

(Fig. 17 : For Heating operation)

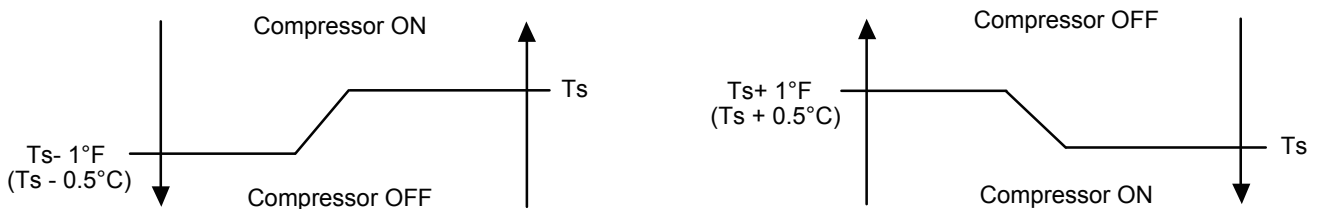

• T_s : Setting temperature

21. BASE HEATER OPERATION (For AOU36RLXFZH)

The base heater is operated as shown in Fig. 18 .

(Fig. 18 : Base heater control)

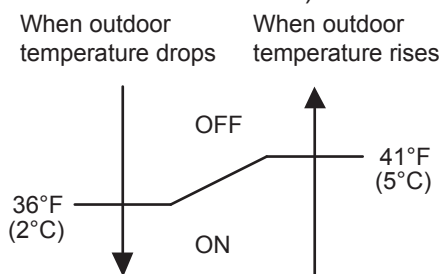

- * When the compressor stops, Base heater is OFF.
- * When the outdoor fan motor stops, Base heater is OFF.
- * In the cooling mode, Base heater is OFF.
- * In the defrost operation, Base heater maintains the same status as before the compressor stops.

22. FRESH AIR CONTROL (For AU type)

The fan motor for Fresh Air is operated in synchronization with the indoor fan operation as shown in Fig. 19 .

(Fig. 19 : Fresh air control)

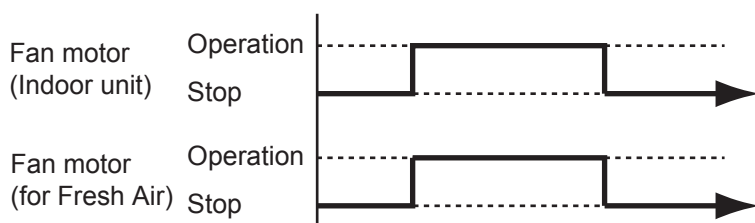

*It needs the external relay and power supply.

23. EXTERNAL ELECTRICAL HEATER CONTROL (For AR type)

The External Electrical Heater is operated as below.

< Heater : ON condition >

When all of the following conditions are met, external electrical heater will operate according to Fig. 20 .

(Table 18 : External electrical heater control)

System type	Heatpump
Operation mode	Heating
Compressor	ON
Indoor fan	ON (S-Lo is excluded)

< Heater : OFF condition >

- 1). When one of the ON conditions is not met.
- 2). When Defrost operation or Oil recovery operation starts

(Fig. 20 : External electrical heater control)

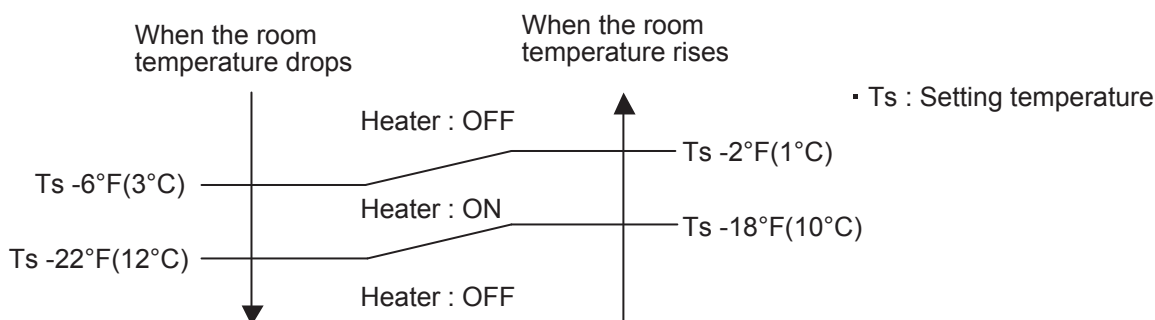

24. DRAIN PUMP OPERATION (For AU / AR type)

During Cooling / Dry mode

1. When the compressor starts, the drain pump starts simultaneously.
2. The drain pump operates continuously for 3 minutes after the compressor is turned off.
3. When the compressor stops by the "Anti- freezing protection", the drain pump is turned off in 1 hour after the compressor stops.
4. When the water level in the drain pan rises up and then the float switch functions:
 - ① The compressor, indoor and outdoor fan motor operation are stopped.
 - ② Drain pump operates continuously for 3 minutes after the float switch is turned off.
 - ③ The indoor unit fan motor operates after the float switch is turned off.
5. When the float switch turns ON continuously for 3 minutes, "FAILURE INDICATION" operates. (It is necessary to turn off power for release it.)
6. When the float switch turns OFF less than 3 minutes, the unit starts Cooling operation.

(Fig. 21 : Detail of drain pump operation in Cooling / Dry)

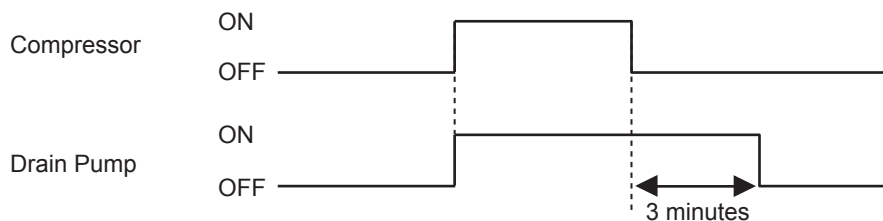

<Float Switch turns OFF less than 3 minutes>

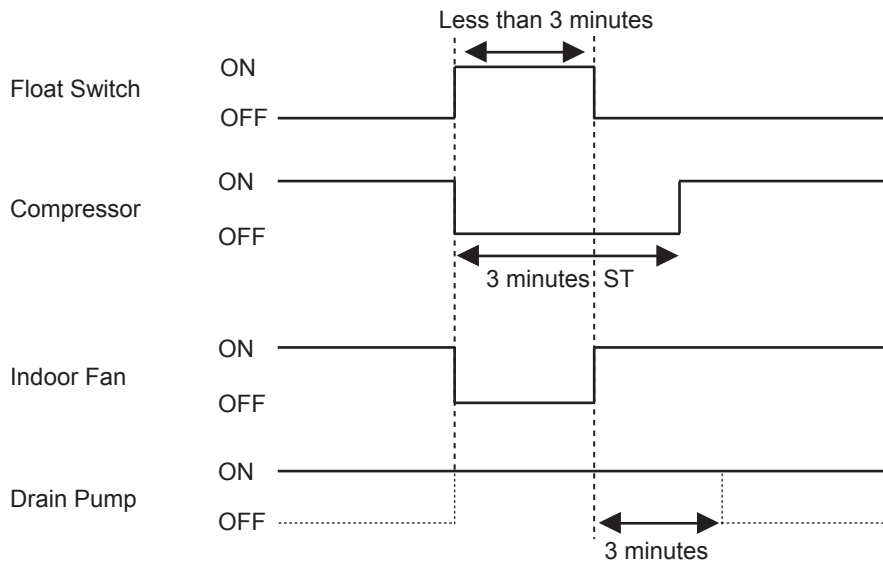

During HEATING / FAN mode / Stop operation

1. When the water level in the drain pan rises up and then the float switch functions:

Drain pump operates continuously for 3 minutes after the float switch is turned off.

(Almost condensing water may be drained)
2. When the float switch turns ON continuously for 3 minutes, "FAILURE INDICATION" operates. Thereafter, even if the float switch turns OFF, the "FAILURE INDICATION" is not released. (It is necessary to turn off power for release it.)

(Fig. 22 : Detail of drain pump operation in Heating)

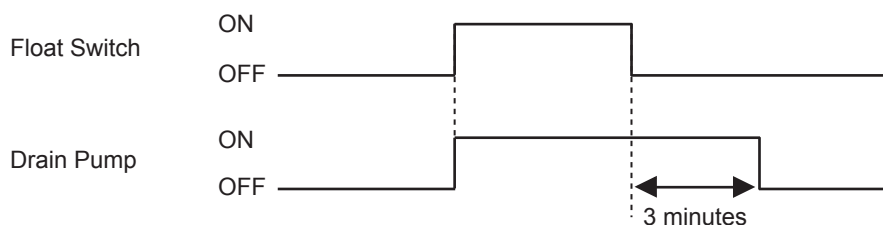

25. AIR OUTLET SELECTION (DAMPER CONTROL)(For AG type)

With this function , air come out simultaneously from the upper and lower air outlets so that the room can be cooled or heated effectively.

This function is set using the switch behind the front grille of the Indoor unit.
(This function is available in cooling and heating operation.)

1. How to set to blow out air from the upper and lower air outlets

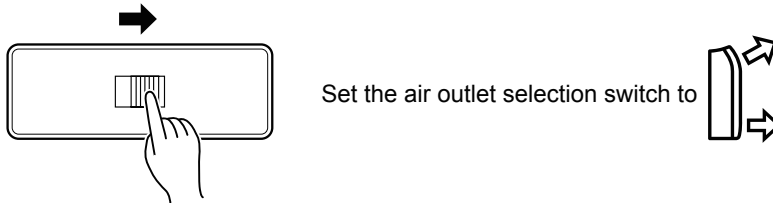

Air blows out automatically from the upper and lower air outlets as shown in Table 19 below.

NOTE: Set the air outlet selection switch to the end.
Otherwise, air outlet cannot be selected as intended.

2. Description of operation

(Table 19 : Damper control)

Operation	COOLING Mode		DRY Mode	HEATING Mode	
Air flow	 Upper and lower air flow	 Upper air flow	 Upper air flow only	 Upper and lower air flow	 Upper air flow
Conditions	Room temperature and set temperature are different.	Room temperature is close to set temperature,*1 or the air conditioner has operated for 1hour.	-	Air flow temperature is high.	Air flow temperature is low.*2 (During defrosting operation, start of operation, etc.)

*1 : In Cooling mode

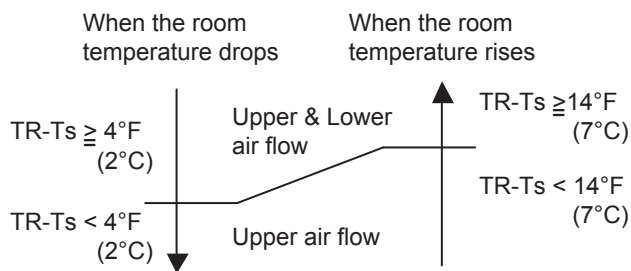

*2 : In Heating mode

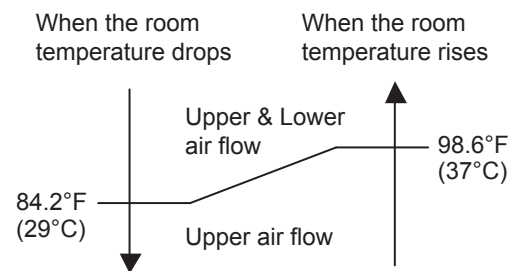

TR : Room temperature Ts : Setting temperature

3. How to set to blow out air from the upper air outlet only

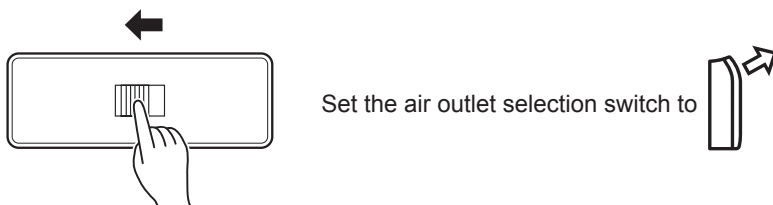

26. DEFROST OPERATION CONTROL

1. CONDITION OF STARTING THE DEFROST OPERATION

The defrost operation starts when the outdoor heat exchanger temperature sensor detects the temperature lower than the values shown in Table 20, 21, 22 .

1-1 NORMAL DEFROST

(Table 20 : Condition of starting defrost operation)

Normal defrost	Compressor integrating operation time	
	Less than 35 minutes	More than 35minutes
	Does not operate	$T_n \leq 1.4^{\circ}\text{F}(-17^{\circ}\text{C})$ (at $T_a \geq 14^{\circ}\text{F}(-10^{\circ}\text{C})$)
		$T_n \leq 0.8 \times T_a - 11.6$ or $T_n \leq -18.4^{\circ}\text{F}(-28^{\circ}\text{C})$ (at $4^{\circ}\text{F}(-20^{\circ}\text{C}) \leq T_a < 14^{\circ}\text{F}(-10^{\circ}\text{C})$)
$T_n \leq 0.8 \times T_a - 11.6$ or $T_n \leq -18.4^{\circ}\text{F}(-28^{\circ}\text{C})$ (at $T_a < 4^{\circ}\text{F}(-20^{\circ}\text{C})$)		
	$T_n - T_{n-1} < 28.4^{\circ}\text{F}(-2^{\circ}\text{C})$ and $S_n = S_{n-1}$ ($T_n \leq 21.2^{\circ}\text{F}(-6^{\circ}\text{C})$)	

T_n : Outdoor heat exchanger temp. S_n : Number of operation indoor units
 T_a : Outside air temp. S_{n-1} : Before 5 minutes detected S_n
 T_{n-1} : Before 5 minutes detected T_n

1-2. INTEGRATING DEFROST

(Table 21 : Condition of integrating defrost operation)

Integrating defrost (OFF count defrost)	Compressor integrating operation time	
	More than 210 minutes (For continuous operation)	
	$T_n \leq 26.6^{\circ}\text{F}(-3^{\circ}\text{C})$ (and after 30 minutes, if the $T_n \leq 26.6^{\circ}\text{F}(-3^{\circ}\text{C})$)	$T_n \leq 23^{\circ}\text{F}(-5^{\circ}\text{C})$ (and after 3 minutes, if the $T_n \leq 23^{\circ}\text{F}(-5^{\circ}\text{C})$)

1-3. INTEGRATING (OFF COUNT) DEFROST

(Table 22 : Condition of integrating (OFF count) defrost operation)

Integrating defrost	Compressor integrating operation time	
	Less than 10 minutes * (For intermittent operation)	
	OFF count of the compressor 40 times (at outside air temp. < $35.6^{\circ}\text{F}(2^{\circ}\text{C})$)	

*If the compressor continuous operation time is less than 10 minutes,
the OFF number of the compressor is counted.
If any defrost operated, the compressor OFF count is cleared.

2. CONDITION OF THE DEFROST OPERATION COMPLETION

Defrost operation is released when the conditions become as shown in Table 23 .

(Table 23 : Defrost release condition)

Release Condition
Outdoor heat exchanger temperature sensor value is higher than $59^{\circ}\text{F}(15^{\circ}\text{C})$ or Compressor operation time has passed 15 minutes.

3. Defrost Flow Chart

The defrosting shall proceed by the integrating operation time, outdoor temperature and outdoor heat exchanger temperature as follows.

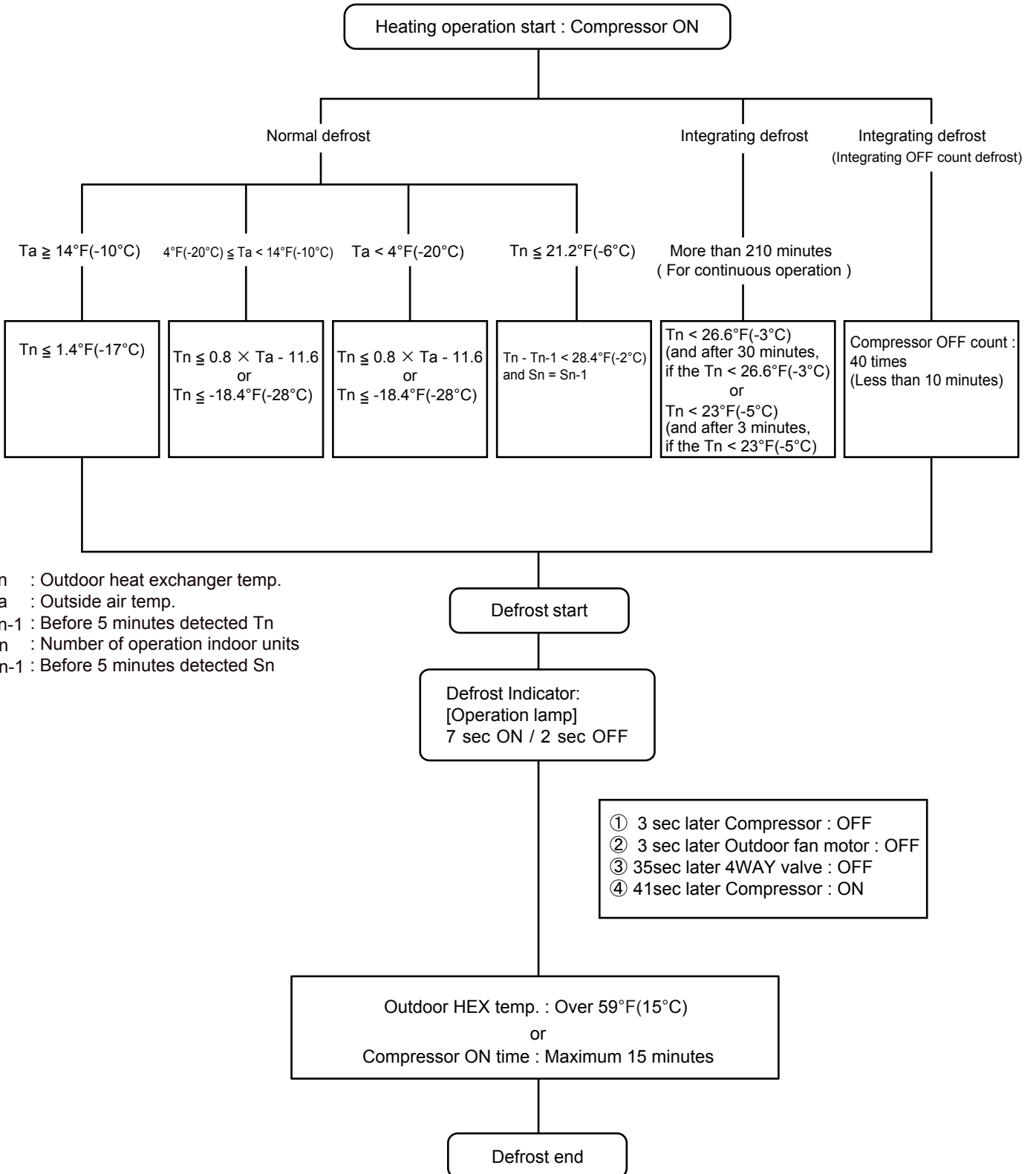

27. CHECK RUN OPERATION (AUTOMATIC WIRING CORRECTION)

If there is a mis-wiring after check operation, switch the indoor unit port automatically on the microcomputer.
(Check operating time)

- Cooling : 30min (Time of approximately)
- Heating : 60min (Time of approximately)

Operating procedure for check run

NOTE : Be sure that the power is turned ON before starting the check run.

(1) Press the "CHECK" switch for 3 seconds or more.

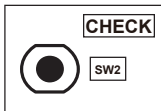

The positions of the switches on the outdoor unit control board are shown in the right.

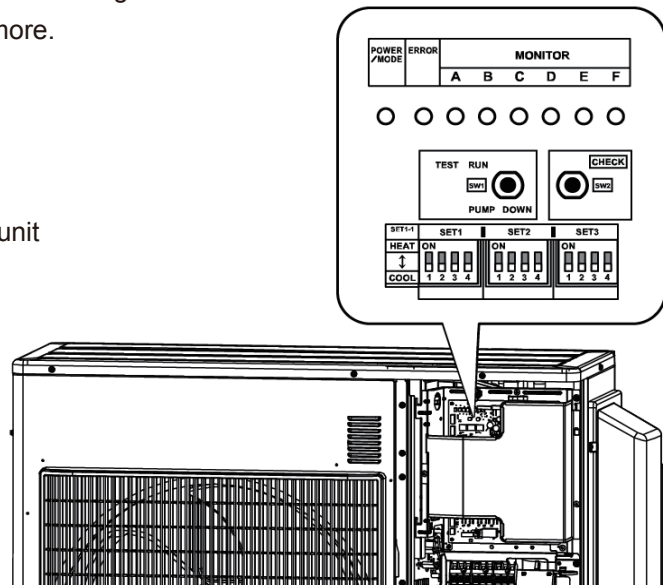

(2) The number of indoor units (and the places) connected through the communication lines is displayed.

- If the displayed number of units (places) and the installed number of units (places) is the same, proceed to step (3).
- If the displayed number of units (places) and the installed number of units (places) is not the same, shut off the power and check whether the indoor and outdoor communication lines are properly connected.
- If there is no operation for 1 minute, the LED will return to the original display. (POWER / MODE LED : ON)

(3) Press the "CHECK" switch for 3 seconds or more again. Check run is initiated.

When check run is initiated, all LEDs from A to F will flash. (Preliminary operation)

The LED for each indoor unit will switch off in order as check for each unit is completed.

To interrupt the check run, press the "CHECK" switch.

Example) When 4 indoor units (A to D) are connected.

POWER / MODE	ERROR	MONITOR					
		A	B	C	D	E	F
		●	●	●	●	○	○



Example) When 4 indoor units (A to D) are connected.

POWER / MODE	ERROR	MONITOR					
		A	B	C	D	E	F
		●	●	●	●	○	○

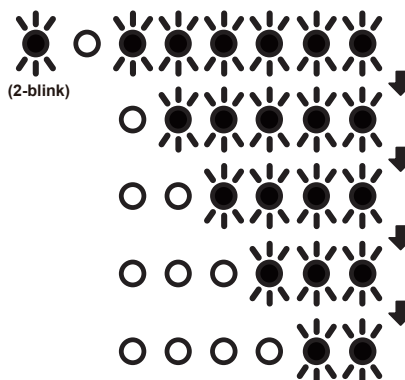

(4) After the check run is complete, results will be displayed. Please fill the display result table accordingly.

NOTE • Automatic wiring correction will not be completed if the power is turned off while displaying the result. To confirm the automatic wiring correction, be sure to carry out step (5).

- If frost is formed on the outdoor unit while displaying the result, Automatic defrost function will operate. Proceed to step (5) after the defrost function is finished.

If the connection is correct [(Example) When 4 indoor units are connected]

After the number of connected units are displayed, the LED for each unit will light up in order from A to D.

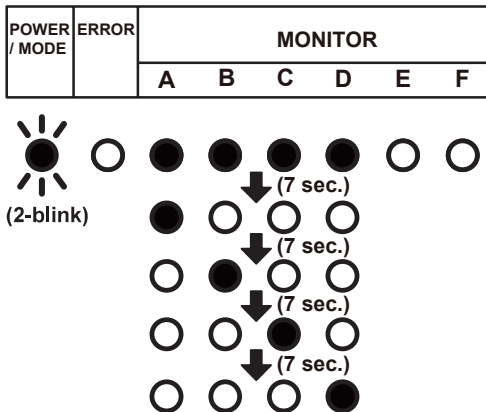

If the connection is incorrect [(Example) When connection of B and C of the 4 units are reversed]

After the number of connected units are displayed, B and C will light up in reverse.

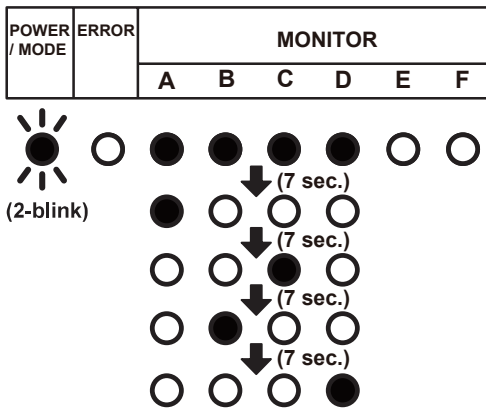

[How to record the contents]

Please fill the displayed result according to the following example.

Example 1

When piping A to D is connected but the wires for B and C are connected in reverse.

Displayed results

The LED will light up in 7 second interval in the following order.

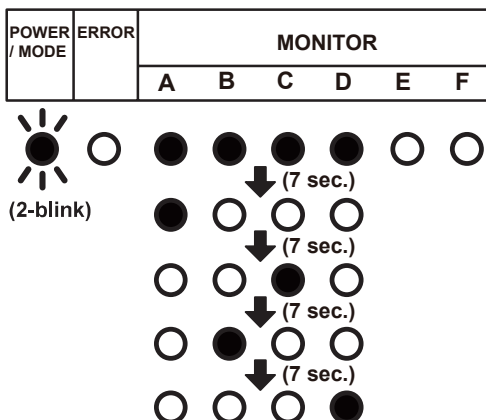

Example of result table

(a) Please write a where the LEDs light up in the order that they light up.

	A	B	C	D	E	F
1	●	●	●	●	○	○
2	●	○	○	○	○	○
3	○	○	●	○	○	○
4	○	●	○	○	○	○
5	○	○	○	●	○	○
6	○	○	○	○	○	○
7	○	○	○	○	○	○

(b) Based on the results of step (a), please record as follows.

Please trace the dotted circle with a pen if multiple places light up.

A	B	C	D	E	F
○	○	○	○	⊖	⊖

Please write the order from A to D in which the LEDs lit up inside the circle.

A	B	C	D	E	F
Ⓐ	Ⓒ	Ⓑ	Ⓓ	⊖	⊖

(c) Select the correction method.



→ Correct the wiring manually.*2
Proceed to step (6).

Use the Automatic wiring correction function.*1
Proceed to step (5).

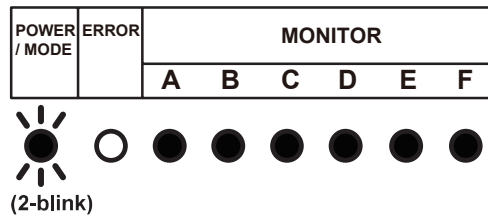

NOTE:

*1 : By using this function, the wiring is automatically corrected according to the piping.

*2 : When correcting the wiring manually, please disconnect the power supply or turn off the breaker during results display, and then change the wiring manually according to the obtained test result.

For example, in Example 1, the wirings connected to the terminals B and C is to be exchanged manually.

Please write down the same results in the label on the reverse side of the service panel.

The results recorded are needed at the time of servicing.

(5) During results display, press the “CHECK” switch for 3 seconds or more.

After LEDs A to F have lit in turn, all LEDs will light up indicating that the automatic wiring correction is completed.

(6) Disconnect the power supply or turn off the breaker and wait 10 minutes then turn the power back on and perform test run.

NOTE: If you do not disconnect the power supply or turn off the breaker, normal operation is not possible.

Others

- If an error occurs during check run it will be suspended. Please correct the error and start check run again.
- After the check run, if automatic wiring correction is carried out, the indoor unit's position will be modified to match the piping. (Please note that the display of the optional remote controller changes.)
- If you start check run again after the automatic wiring correction is finished, the modification will be reset.

Check run judgment failure display

- If check run cannot be performed, the following is displayed. In this case, the check run will stop. Please check by using the cooling test run of the indoor unit.

Temperature out of range judgment

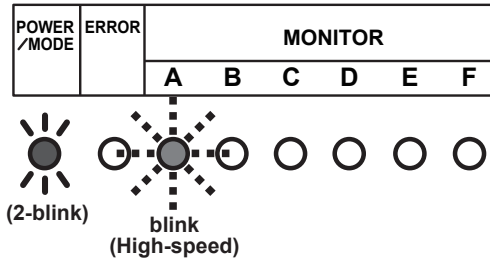

Wiring / piping number difference

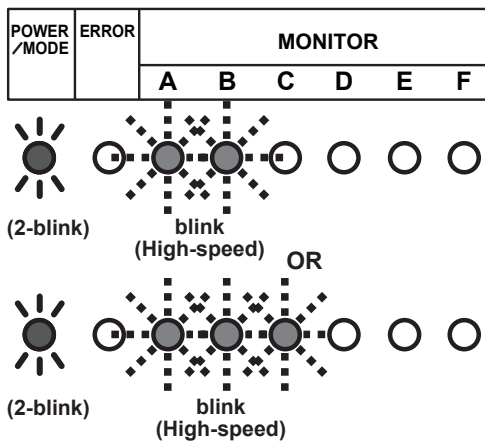

Re-display check run results

- If you wish to check the automatic wiring correction contents, by briefly pressing the "CHECK" switch, the check run results is displayed. Please check the check run results by referring to the result table in step (4) of "8.3. Operating procedure for check run".
- If the automatic wiring correction contents has not been done, the POWER/MODE LED will blink twice and the MONITOR LED will turn off.

Automatic wiring correction memory reset

⚠ CAUTION

When relocating the unit, reset the memory beforehand, or the unit may not function normally.

- Press the "CHECK" switch.
The LED will light as shown in "8.5 Re-display check run results".
- Press the "CHECK" switch for more than 3 seconds when the LED is on.
- The LEDs from A to F will light in sequence, and then all LEDs will light to indicate the completion of the Automatic wiring correction memory reset.
- Disconnect the power supply or turn off the breaker.

28. VARIOUS PROTECTIONS

1. DISCHARGE GAS TEMPERATURE OVER RISE PREVENTION CONTROL

The discharge gas thermosensor (discharge thermistor : Outdoor side) will detect discharge gas temperature.

When the discharge temperature becomes higher than Temperature I , the compressor frequency is decreased 30rps, and it continues to decrease the frequency for 30rps every 120 seconds until the temperature becomes lower than Temperature II.

When the discharge temperature becomes lower than Temperature II ,the control of the compressor frequency is released.

When the discharge temperature becomes higher than Temperature III ,the compressor stops.

(Table 24 : Discharge temperature over rise prevention control / Release temperature)

	Temperature I	Temperature II	Temperature III
AOU36RLXFZH AOU45RLXFZ	219°F (104°C)	214°F (101°C)	230°F (110°C)

2. CURRENT RELEASE CONTROL

The compressor frequency is controlled so that the outdoor unit input current does not exceeds the current limit value that was set up with the outdoor temperature.

The compressor frequency returns to the designated frequency of the indoor unit at the time when the frequency becomes lower than the release value.

3. COOLING PRESSURE OVER RISE PROTECTION

When the outdoor unit discharge pressure sensor rises to 580.2 psi (4 MPa) or greater, the compressor is stopped and error display is indicated.

4. HIGH TEMPERATURE RELEASE CONTROL (Heating mode)

On heating mode, the compressor frequency is controlled as following based on the detection value of the discharge pressure sensor.

(Fig. 23 : Heating overload protection control)

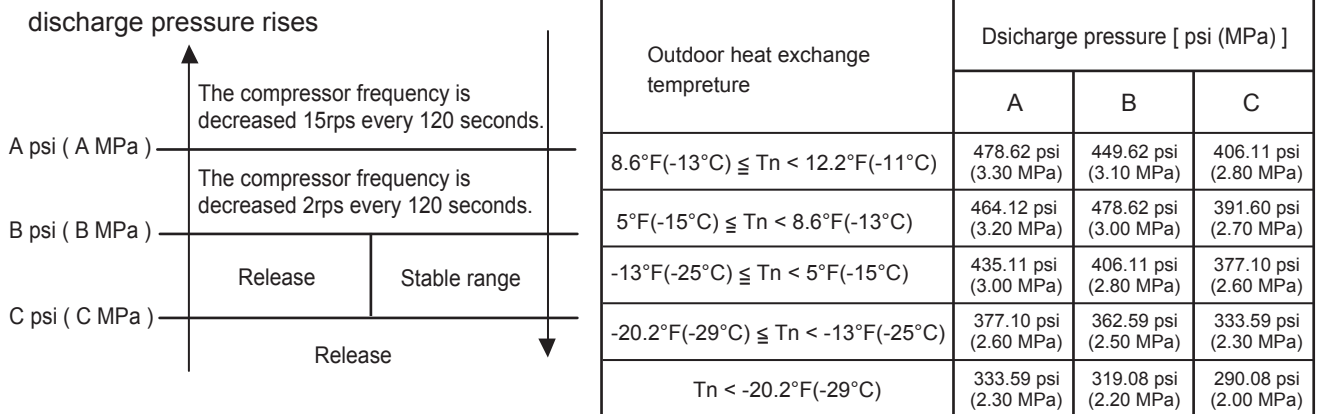

5. HIGH PRESSURE PROTECTION

During the compressor operation, when detect the condition of the following table value, the protection function will be worked.

The operation condition varies according to the compressor speed.

The protection function is, the compressor speed is decreased 7 rps every 60 seconds.

(Table 26 : Cooling operation)

Compressor frequency [rps]	Operation value [psi (MPa)]	Release value [psi (MPa)]
rps ≤ 20	Hp ≥ 500.38 psi (3.45 MPa)	Hp ≤ 471.37 psi (3.25 MPa)
20 < rps ≤ 90	Hp ≥ 551.14 psi (3.80 MPa)	Hp ≤ 522.14 psi (3.60 MPa)
90 < rps ≤ 100	Hp ≥ 478.62 psi (3.30 MPa)	Hp ≤ 449.62 psi (3.10 MPa)

(Table 27 : Heating operation)

Compressor frequency [rps]	Operation value [psi (MPa)]	Release value [psi (MPa)]
rps ≤ 20	Hp ≥ 500.38 psi (3.45 MPa)	Hp ≤ 471.37 psi (3.25 MPa)
20 < rps ≤ 90	Hp ≥ 507.63 psi (3.50 MPa)	Hp ≤ 478.62 psi (3.30 MPa)
90 < rps ≤ 100	Hp ≥ 478.62 psi (3.30 MPa)	Hp ≤ 449.62 psi (3.10 MPa)
100 < rps	Hp ≥ 449.62 psi (3.10 MPa)	Hp ≤ 420.61 psi (2.90 MPa)

Hp : detected discharge pressure sensor value

rps : detected compressor frequency

6. COMPRESSOR TEMPERATURE PROTECTION

Compressor temperature sensor is monitoring the compressor Temperature I

When the compressor temperature sensor detects higher than Temperature I , the compressor is stopped.

When 3 minutes has passed from the compressor stop and the compressor temperature sensor detects lower than Temperature II, protection is released and the compressor will restart.

(Table 28 : Operation value)

	Temperature I	Temperature II
AOU36RLXFZH	226°F	176°F
AOU45RLXFZ	(108°C)	(80°C)

29. PUMP DOWN OPERATION

When moving or discarding the air conditioner, in order to consider the environment and avoid the discharge of refrigerant to the atmosphere, please pump down according to the following procedure.

- (1) Connect the pressure gauge to the charging port.
- (2) Change the DIP switch on the board (SET1-2) to ON*1

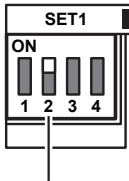

*1: DIP switch (SET1-2)

*Be sure the power supply is disconnected on the breaker is turned off when changing the DIP switch.

WARNING

During the pump down operation, make sure that compressor is off before you remove the refrigerant piping. Do not remove the connection pipe while the compressor is in operation with valve open. This may cause abnormal pressure in the refrigeration cycle that leads to breakage and even injury.

- (3) To start operation, press the [PUMP DOWN] switch*2 for 3 seconds or press after the power has been on for 3 min.

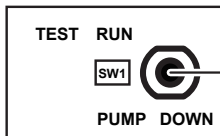

*2: Push switch (SW1)

During pump down, the LED (POWER/MODE) will flash 3 times consecutively.

POWER /MODE	ERROR	MONITOR					
		A	B	C	D	E	F



NOTE:

If the [PUMP DOWN] switch is pressed during compressor operation, the compressor will stop, and the operation will start after about 3 min.

- (4) Close the liquid pipe valve.
- (5) When 7.3 psi ~ 0 psi (0.05 MPa ~ 0 MPa) is shown, close the gas pipe valve.
- (6) Stop pump down by pressing the [PUMP DOWN] switch for 3 seconds.
The LED will light as follows.

POWER /MODE	ERROR	MONITOR					
		A	B	C	D	E	F



- (7) Disconnect the power supply or turn off the breaker.

NOTE:

- If the pump down is not stopped by pressing the switch as in step (6), it will stop automatically after 15 min. and the LED will light as follows. If the pump down is complete, disconnect the power supply or turn off the breaker. If not completed open the liquid pipe valve, and then start again from step (3).

POWER /MODE	ERROR	MONITOR					
		A	B	C	D	E	F

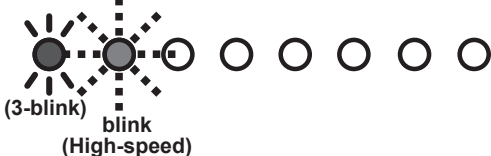

- In order to interrupt the pump down operation, press the [PUMP DOWN] switch again. The LED will return to the original display before starting pump down. (POWER/MODE LED: On)
- The pump down may stop before completion due to error. To complete the pump down, correct the error, open the liquid pipe valve and then start from step (1) again. Otherwise, the refrigerant can be recovered from the service port.

30. TEST RUN (For Outdoor unit)

⚠ CAUTION

Always turn on the power 12 hours prior to the start of the operation in order to protect the compressor.

(1) Indoor unit

- 1 Is the drain normal?
- 2 Is there any abnormal noise and vibration during operation?

(2) Outdoor unit

- 1 Is there any abnormal noise and vibration during operation?
- 2 Will noise, wind, or drain water from the unit disturb the neighbors?
- 3 Is there any gas leakage?
 - Do not operate the air conditioner in the test running state for a long time.
 - For the operation method of the test run for indoor unit and central remote controller, refer to the operating manual and perform operation check.

TEST RUN method

Be sure to turn the power off before starting the test run.

- (1) Check the 3-way valves (both at the liquid side and gas side) are opened. Please confirm that the DIP switch SET1-2 is switched OFF.
- (2) Set the operation mode to "COOL" or "HEAT". If you wish to the DIP switch SET1-1 to "HEAT", please switch it after temporarily disconnecting the power supply or turning off the breaker switching the power off.

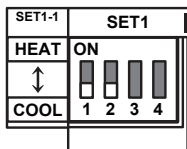

- In the first test run, be sure to set the operation mode to "COOL".
 - The operation mode cannot be switched between "COOL" and "HEAT" during the test run. To switch the operation mode between "COOL" and "HEAT", stop the test run, switch the operation mode, and then start the test run again.
- (3) Press "TEST RUN" switch for more than 3 seconds.
The POWER / MODE LED flashes once.

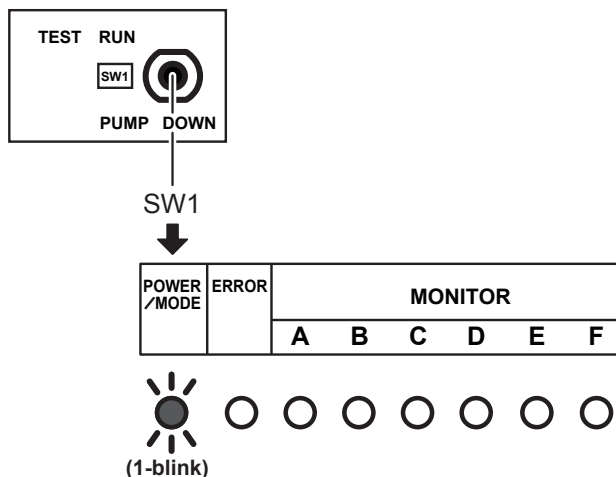

- (4) Confirm operating status.
- (5) Press "TEST RUN" switch for more than 3 seconds.

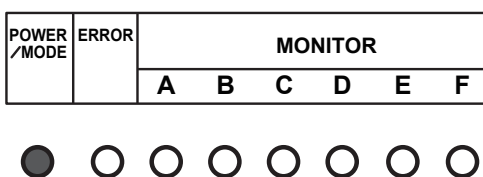

POWER/MODE LED will turn on, and test run stops.

***Slim Duct / Compact Cassette
Compact Wall Mounted /
Wall Mounted / Floor type***

INVERTER (MULTI)

2 . TROUBLE SHOOTING

2-1 ERROR DISPLAY

2-1-1 INDOOR UNIT AND WIRED REMOTE CONTROLLER DISPLAY

Please refer the flashing pattern as follows.

The Operation, Timer, Economy lamps operate as follows according to the error contents.

Error Contents	Indoor Unit Display			Wired Remote Controller Display	Trouble shooting
	Operation (Green)	Timer (Orange)	Economy (Green)		
Serial Communication Error	1 times	1 times	Continuous	11	1,2
Wired Remote Controller Communication Error	1 times	2 times	Continuous	12	3
Indoor Unit Capacity Error	2 times	2 times	Continuous	22	5
Indoor Unit Model Information Error EEPROM Access Abnormal	3 times	2 times	Continuous	32	6
Manual Auto Switch Error	3 times	5 times	Continuous	35	7
Indoor Room Thermistor Error	4 times	1 times	Continuous	41	8
Indoor Heat Ex. Thermistor Error	4 times	2 times	Continuous	42	9
Indoor Unit Fan Motor Error	5 times	1 times	Continuous	51	10
Drain Pump Error	5 times	3 times	Continuous	53	11
Damper Error	5 times	7 times	Continuous	57	12,13
Intake Grille Error	5 times	8 times	Continuous	58	14
Outdoor Unit Model Information Error	6 times	2 times	Continuous	62	15
Inverter Communication Error	6 times	2 times	Continuous	62	17
Inverter Error	6 times	3 times	Continuous	63	19
Active Filter Error	6 times	4 times	Continuous	64	20
IPM Error	6 times	5 times	Continuous	65	21
Discharge Thermistor Error	7 times	1 times	Continuous	71	22
Compressor Thermistor Error	7 times	2 times	Continuous	72	23
Heat Ex. Thermistor Error (OUT)	7 times	3 times	Continuous	73	24
Outdoor Thermistor Error	7 times	4 times	Continuous	74	25
2-Way Valve Thermistor Error	7 times	6 times	Continuous	76	26
3-Way Valve Thermistor Error	7 times	6 times	Continuous	76	27
CT Error	8 times	4 times	Continuous	84	28
Discharge Pressure Sensor Error	8 times	6 times	Continuous	86	29
Over Current Error	9 times	4 times	Continuous	94	30
Compressor Control Error	9 times	5 times	Continuous	95	31
Outdoor Unit Fan Motor Error	9 times	7 times	Continuous	97	32
4-Way Valve Error	9 times	9 times	Continuous	99	33
Coil (expansion valve) Error	9 times	10 times	Continuous	9A	34
Discharge Temp. Error	10 times	1 times	Continuous	A1	35
Compressure Temp. Error	10 times	3 times	Continuous	A3	36

1. SELF - DIAGNOSIS

When " Er " in Temperature Display is displayed, inspection of the air conditioning system is necessary. Please consult authorized service personnel.

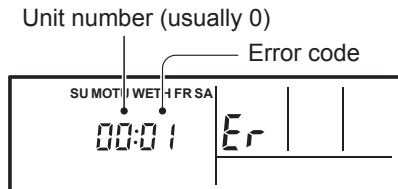

ex. Self-diagnosis check

2. ERROR CODE HISTORY DISPLAY

Up to 16 memorized error codes may be displayed for the indoor unit connected to the remote controller.

1. Stop the air conditioner operation.

2. Press the SET TEMPERATURE buttons ∇ , \blacktriangle simultaneously for 3 seconds or more to start the self-diagnosis.

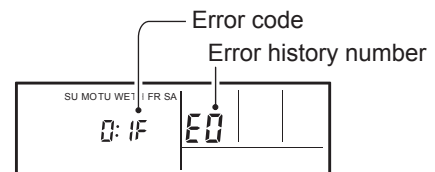
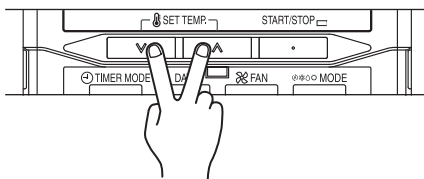

3. Press the SET TEMPERATURE button to select the error history number.

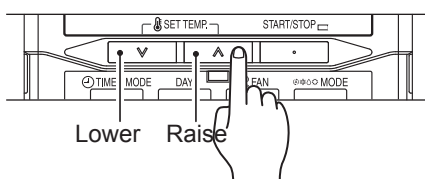

0 ↔ 1 ↔ 2 ↔ 3 ↔ 4 ↔ 5 ↔ 6 ↔ 7
 F ↔ E ↔ d ↔ c ↔ b ↔ A ↔ 9 ↔ 8

4. Press the SET TEMPERATURE buttons ∇ , \blacktriangle simultaneously for 3 seconds or more or there is no key input for 60 seconds to stop the display.

2-1-2 SIMPLE REMOTE CONTROLLER DISPLAY

If an error occurs, the following display will be shown.
 ("Er" will appear in the set room temperature display.)
 If "Er" is displayed, immediately contact authorized service personnel.

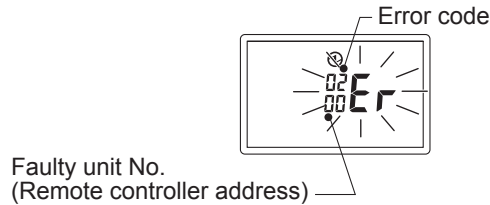

Ex. Error code display

2-1-3 CENTRAL REMOTE CONTROLLER DISPLAY

To show which indoor unit is the error displayed,
 indoor unit's name and "ERROR" are alternately shown.
 (0.5s indoor unit's name / 0.5s "ERROR")

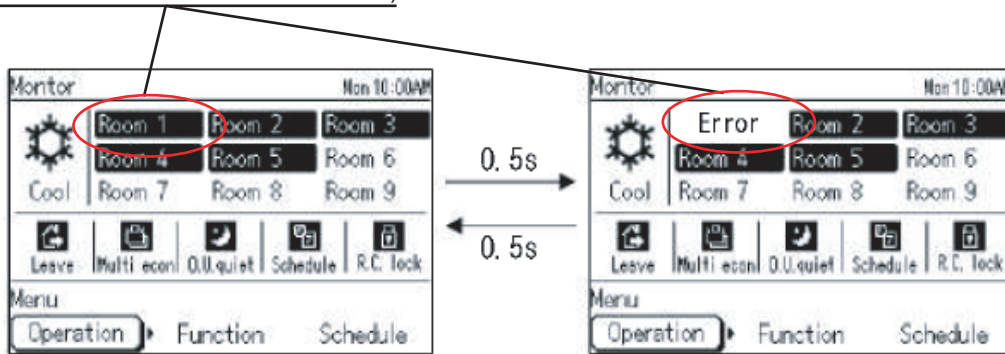

Ex. Error display

2-1-4 OUTDOOR UNIT DISPLAY

• If an error occurs, the LED will light up to display the error location and the error code.

In the event of an error

• The error LED flashes quickly.

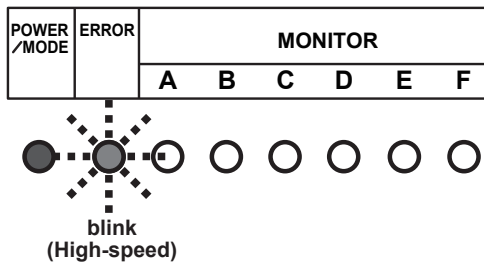

Error location display

• LEDs A to F of MONITOR light up and display the error location. In the case of an overall error, LEDs A to F of MONITOR do not light up.

Example) Coil error in indoor unit B

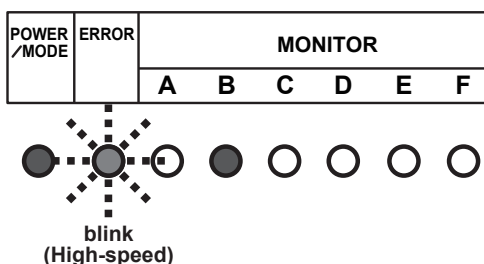

Error code display

While the error is occurring, please briefly press SW1.
The error code is displayed.

Ex.) Serial communication error (Error cord = 11.3)

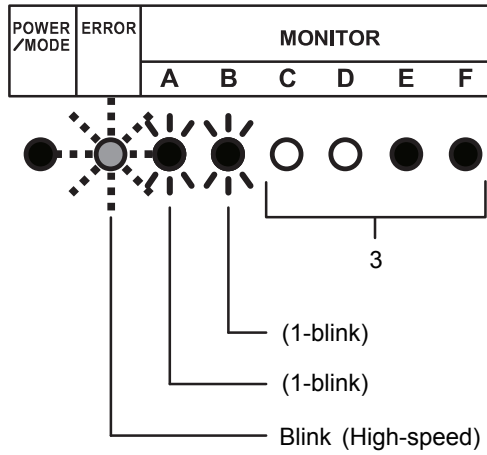

Display mode

LED on : ●

LED off : ○



Blink :

(0.5s Light on / 0.5s Light off)

For MONITOR

(A and B)

A : 10 - Blink

C : 11 - Blink

F : 12 - Blink

J : 13 - Blink

P : 14 - Blink

U : 15 - Blink

C	D	E	F	
○	○	○	●	➔ 1
○	○	●	○	➔ 2
○	○	●	●	➔ 3
○	●	○	○	➔ 4
○	●	○	●	➔ 5
○	●	●	○	➔ 6
○	●	●	●	➔ 7
●	○	○	○	➔ 8
●	○	○	●	➔ 9
●	○	●	○	➔ A
●	○	●	●	➔ C
●	●	○	○	➔ F
●	●	○	●	➔ J
●	●	●	○	➔ P
●	●	●	●	➔ U

Error code	Error contents	Outdoor unit LED display part						Trouble shooting
		Monitor						
		A	B	C	D	E	F	
11. 3	Serial communication error	● 1	● 1	○	○	●	●	2
11. 4	Serial communication error during operation	● 1	● 1	○	●	○	○	2
16. 5	Communication error between controller and outdoor unit	● 1	● 6	○	●	○	●	4
22. 1	Indoor unit capacity error	● 2	● 2	○	○	○	●	5
5U. 1	Indoor unit error	● 5	● 15	○	○	○	●	3,6~14
62. 1	PCB model information error	● 6	● 2	○	○	○	●	15
62. 3	EEPROM access error	● 6	● 2	○	○	●	●	16
62. 6	Inverter communication error	● 6	● 2	○	●	●	○	17
62. 8	EEPROM data corruption error	● 6	● 2	●	○	○	○	18
63. 1	Inverter error	● 6	● 3	○	○	○	●	19
65. 3	IPM error (Trip terminal L error)	● 6	● 5	○	○	●	●	21
71. 1	Discharge temp. sensor error	● 7	● 1	○	○	○	●	22
72. 1	Compressor temp. sensor error	● 7	● 2	○	○	○	●	23
73. 3	Heat ex. liquid temp. sensor error	● 7	● 3	○	○	●	●	24
74. 1	Outdoor temp. sensor error	● 7	● 4	○	○	○	●	25
76. 1	valve sensor error	● 7	● 6	○	○	○	●	26
76. 2		● 7	● 6	○	○	●	○	27
84. 1	Current sensor 1 error (stoppage permanently)	● 8	● 4	○	○	○	●	28
86. 1	Discharge pressure sensor error	● 8	● 6	○	○	○	●	29
94. 1	Trip detection	● 9	● 4	○	○	○	●	30
95. 1	Compressor motor control error	● 9	● 5	○	○	○	●	31
97. 3	Fan motor 1 error(Duty error)	● 9	● 7	○	○	●	●	32
99. 1	4-way valve error	● 9	● 9	○	○	○	●	33
9A. 1	Coil 1 (expansion valve 1) error	● 9	● 10	○	○	○	●	34
A1. 1	Discharge temperature 1 error (stoppage permanently)	● 10	● 1	○	○	○	●	35
A3. 1	Compressor 1 temperature error	● 10	● 3	○	○	○	●	36

This Error code list is excerpt by instalation manual.

● : Flashing ○ : No indication

● 1 - 15 : Outdoor LED Blink (1 to 15 times) 0.5s Light on / 0.5s Light off

NOTE

Error code 16.5 : Occur when using the Home remote controller.

Error code 5U.1 : Indoor unit all error

2-2 TROUBLE SHOOTING WITH ERROR CODE

Trouble shooting 1 OUTDOOR UNIT Error Method: Serial Communication Error (Serial Reverse Transfer Error)	Indicate or Display: Indoor Unit Operation lamp : 1 time Flash Timer lamp : 1 time Flash ERROR CODE : [E : 11]	Outdoor Unit: No indication

Detective Actuators: Outdoor unit main PCB Outdoor unit fan motor	Detective details: When the indoor unit cannot receive the serial signal from outdoor unit more than 2 minutes after power ON, or the indoor unit cannot receive the serial signal more than 15 seconds during normal operation.
--	--

Forecast of Cause: 1. Connection failure 2. External cause 3. Main PCB failure 4. Active filter module failure 5. Transistor PCB (IPM) failure 6. Filter PCB failure 7. Outdoor unit Fan motor failure

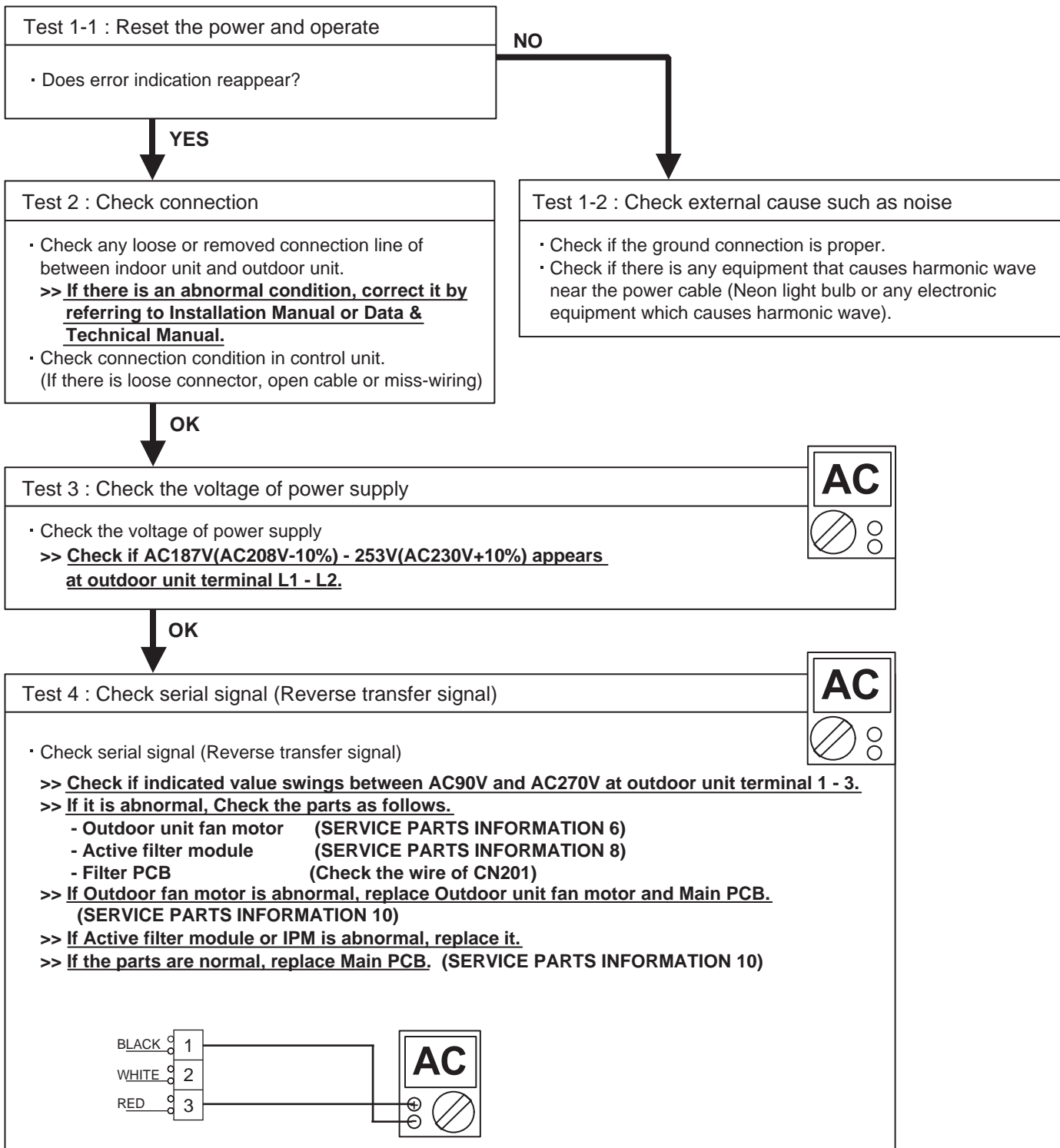

Trouble shooting 2 INDOOR UNIT Error Method: Serial Communication Error (Serial Forward Transfer Error)	Indicate or Display: Indoor Unit Operation lamp : 1 time Flash Timer lamp : 1 time Flash ERROR CODE : [E : 11]	Outdoor Unit <table border="1" style="margin-left: auto; margin-right: auto;"> <thead> <tr> <th colspan="6">Monitor</th> </tr> <tr> <th>A</th> <th>B</th> <th>C</th> <th>D</th> <th>E</th> <th>F</th> </tr> </thead> <tbody> <tr> <td>● 1</td> <td>● 1</td> <td>○</td> <td>○</td> <td>●</td> <td>●</td> </tr> <tr> <td>● 1</td> <td>● 1</td> <td>○</td> <td>●</td> <td>○</td> <td>○</td> </tr> </tbody> </table> <p style="text-align: center; font-size: small;">● : Light ON ○ : Light OFF ●n : n time blinking</p>	Monitor						A	B	C	D	E	F	● 1	● 1	○	○	●	●	● 1	● 1	○	●	○	○
Monitor																										
A	B	C	D	E	F																					
● 1	● 1	○	○	●	●																					
● 1	● 1	○	●	○	○																					

Detective Actuators: Indoor unit controller PCB	Detective details: When the outdoor unit cannot properly receive the serial signal from indoor unit for 15 seconds or more.
---	---

Forecast of Cause:
 1. Connection failure 2. External cause 3. Controller PCB failure

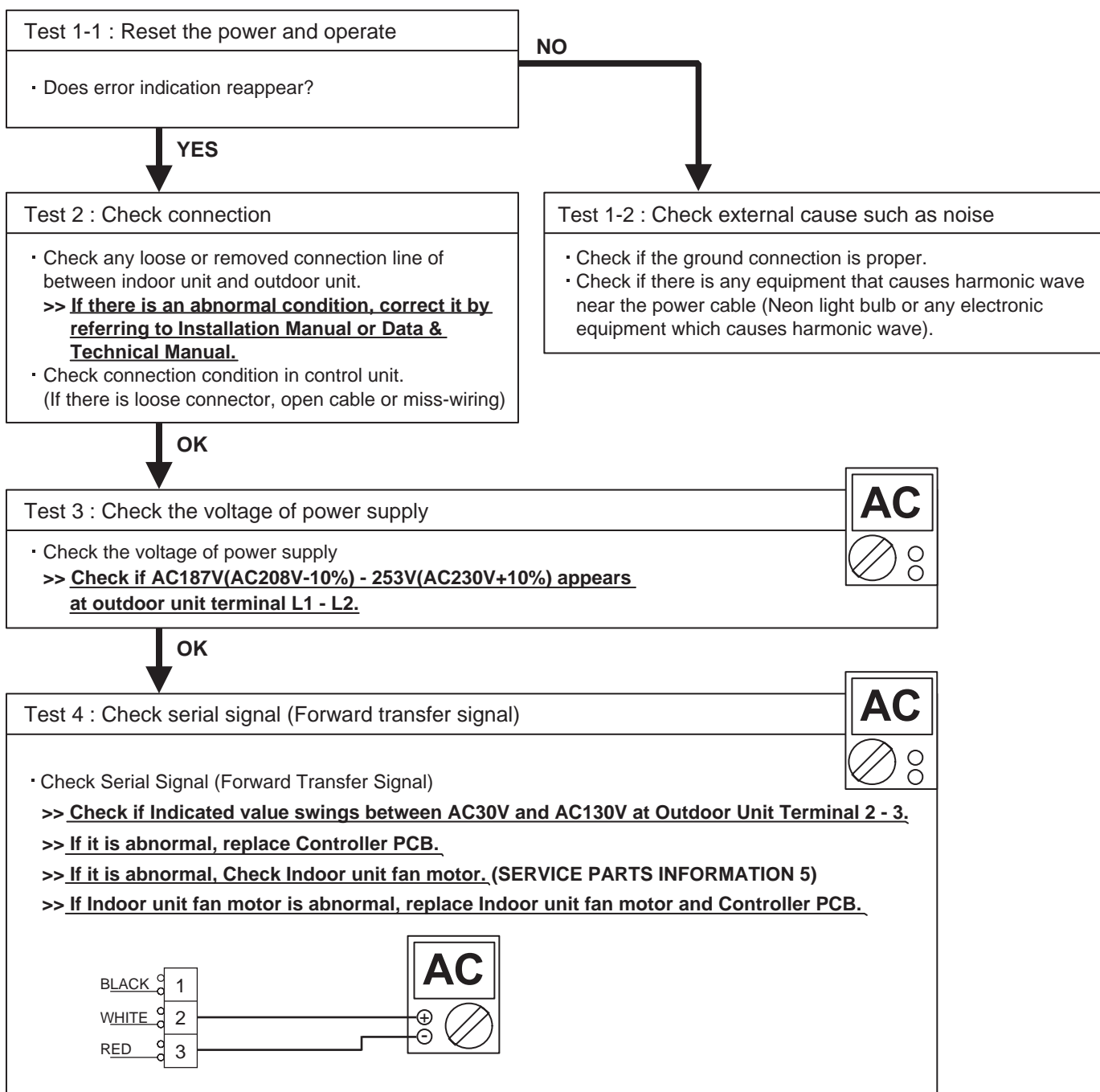

<p>Trouble shooting 3 INDOOR UNIT Error Method: Wired Remote Controller Communication Error</p>	<p>Indicate or Display: Indoor Unit Operation lamp : 1 time Flash Timer lamp : 2 time Flash ERROR CODE : [E : 12]</p>	<p>Outdoor Unit</p> <table border="1" style="width: 100%; border-collapse: collapse; text-align: center;"> <tr> <th colspan="6">Monitor</th> </tr> <tr> <th>A</th> <th>B</th> <th>C</th> <th>D</th> <th>E</th> <th>F</th> </tr> <tr> <td>● 5</td> <td>● 15</td> <td>○</td> <td>○</td> <td>○</td> <td>●</td> </tr> </table> <p>● : Light ON ○ : Light OFF ● n : n time blinking</p>	Monitor						A	B	C	D	E	F	● 5	● 15	○	○	○	●
Monitor																				
A	B	C	D	E	F															
● 5	● 15	○	○	○	●															

<p>Detective Actuators: Indoor unit controller PCB Wired remote controller</p>	<p>Detective details: When the indoor unit cannot properly receive the signal from Wired Remote Controller for 1 minutes or more.</p>
---	---

Forecast of Cause:
 1. Connection failure 2. Wired Remote Controller failure 3. Controller PCB failure

Test 1 : Check the connection of terminal

Check & correct the followings.

- Check the connection of terminal between Wired Remote Controller and indoor unit, and check if there is a disconnection of the cable.



<p>Test 2 : Check Wired Remote Controller and Controller PCB</p> <ul style="list-style-type: none"> • Check Voltage at terminal 1-3 of Controller PCB or Communication PCB. (Power supply to Remote Control) Compact Cassette, Slim Duct Type : CN14 Wall Mount , Floor Type : CN16 Compact Wall Mount Type : CNC01 (UTY-XCBXZ2) <p>>> If it is DC12V, Remote Control is failure. (Controller PCB is normal) >> Replace Remote Control >> If it is DC 0V, Controller PCB is failure. (Check Remote Control once again) >> Replace Controller PCB</p>	<div style="border: 1px solid black; padding: 2px; width: 40px; margin: 0 auto;"> <p style="margin: 0;">DC</p> </div>
--	--

<p>Trouble shooting 4 OUTDOOR UNIT Error Method: Communication Error Between Controller And Outdoor Unit</p>	<p>Indicate or Display: Indoor Unit Operation lamp : - time Flash Timer lamp : - time Flash ERROR CODE : [E : --]</p>	<p>Outdoor Unit</p> <table border="1" data-bbox="1161 347 1572 428"> <thead> <tr> <th colspan="6">Monitor</th> </tr> <tr> <th>A</th> <th>B</th> <th>C</th> <th>D</th> <th>E</th> <th>F</th> </tr> </thead> <tbody> <tr> <td>● 1</td> <td>● 6</td> <td>○</td> <td>●</td> <td>○</td> <td>●</td> </tr> </tbody> </table> <p>● : Light ON ○ : Light OFF ● n : n time blinking</p>	Monitor						A	B	C	D	E	F	● 1	● 6	○	●	○	●
Monitor																				
A	B	C	D	E	F															
● 1	● 6	○	●	○	●															

<p>Detective Actuators: Outdoor unit Main PCB Home Controller</p>	<p>Detective details: When the home controller cannot 60sec receive the signal from</p>
--	---

<p>Forecast of Cause: 1. Connection failure 2. Home Controller failure 3. Main PCB failure</p>
--

<p>Test 1 : Check the connection of terminal</p> <p><u>Check & correct the followings.</u> • Check the connection of terminal between Wired Remote Controller and indoor unit, and check if there is a disconnection of the cable.</p>
--



<p>Test 2 : Check Home Controller and Main PCB</p> <p>• Check Voltage at terminal 1-3 (CN93) of Main PCB. (Power supply to Remote Control)</p> <p>>> If it is DC12V, Home Controller is failure. (Main PCB is normal) >> Replace Home Controller >> If it is DC 0V, Main PCB is failure. (Check Home Controller once again) >> Replace Main PCB (SERVICE PARTS INFORMATION 10)</p>	<div style="border: 1px solid black; padding: 5px; width: 40px; margin: 0 auto;"> DC  </div>
---	---

<p>Trouble shooting 5 INDOOR UNIT Error Method: Indoor Unit Capacity Error</p>	<p>Indicate or Display: Indoor Unit Operation lamp : 2 time Flash Timer lamp : 2 time Flash ERROR CODE : [E : 22]</p>	<p>Outdoor Unit</p> <table border="1" data-bbox="1121 299 1532 383"> <thead> <tr> <th colspan="6">Monitor</th> </tr> <tr> <th>A</th> <th>B</th> <th>C</th> <th>D</th> <th>E</th> <th>F</th> </tr> </thead> <tbody> <tr> <td>● 2</td> <td>● 2</td> <td>○</td> <td>○</td> <td>○</td> <td>●</td> </tr> </tbody> </table> <p>● : Light ON ○ : Light OFF ● n : n time blinking</p>	Monitor						A	B	C	D	E	F	● 2	● 2	○	○	○	●
Monitor																				
A	B	C	D	E	F															
● 2	● 2	○	○	○	●															

<p>Detective Actuators: All indoor unit</p>	<p>Detective details: The total capacity of the indoor unit if it is install beyond.</p>
---	--

Forecast of Cause:
1. The selection of indoor units is incorrect 2. Main PCB(Outdoor unit) failure

Test 1 : Check the total capacity of indoor unit

· Check the total capacity of the connected indoor units.
>> If abnormal condition is found, correct it by referring to Installation Manual or Design & Technical Manual.



Test 2 : Replace Main PCB

▶ **If Test 1 do not improve the symptom, replace Main PCB of Outdoor unit.**
(SERVICE PARTS INFORMATION 10)

Trouble shooting 6 INDOOR UNIT Error Method: Indoor Unit Model Information Error EEPROM Access Abnormal	Indicate or Display: Indoor Unit Operation lamp : 3 time Flash Timer lamp : 2 time Flash ERROR CODE : [E : 32]	Outdoor Unit <table border="1" style="margin-left: auto; margin-right: auto;"> <thead> <tr> <th colspan="6">Monitor</th> </tr> <tr> <th>A</th> <th>B</th> <th>C</th> <th>D</th> <th>E</th> <th>F</th> </tr> </thead> <tbody> <tr> <td style="text-align: center;">● 5</td> <td style="text-align: center;">● 15</td> <td style="text-align: center;">○</td> <td style="text-align: center;">○</td> <td style="text-align: center;">○</td> <td style="text-align: center;">●</td> </tr> </tbody> </table> <p style="text-align: center; font-size: small;">● : Light ON ○ : Light OFF ● n : n time blinking</p>	Monitor						A	B	C	D	E	F	● 5	● 15	○	○	○	●
Monitor																				
A	B	C	D	E	F															
● 5	● 15	○	○	○	●															

Detective Actuators: Indoor unit controller PCB	Detective details: When power is on and there is some below case. ① When model information of EEPROM is oncorrect. ② When the access to EEPROM failed.
---	--

Forecast of Cause:
 1. External cause 2. Defective connection of electric components 3. Controller PCB failure

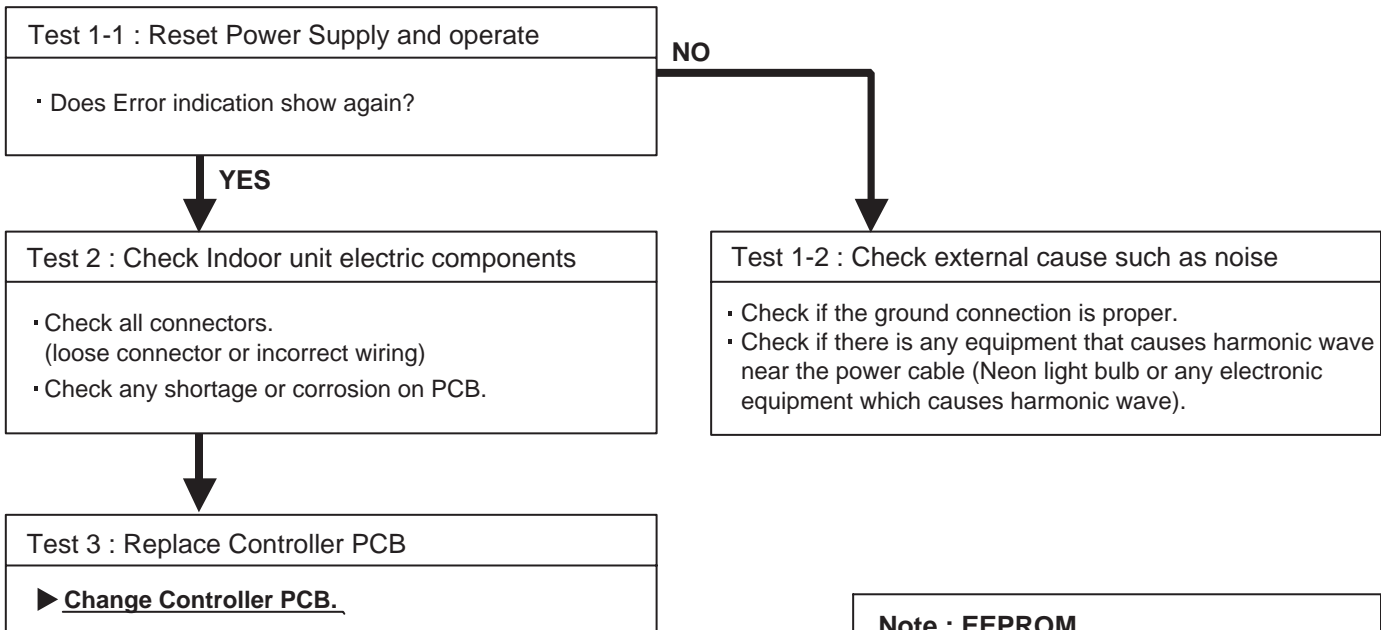

Note : EEPROM
 EEPROM(Electronically Erasable and Programmable Read Only Memory) is a non-volatile memory which keeps memorized information even if power is turned off. It can change the contents electronically. To change the contents, it uses higher voltage than normal, and it can not change a partial contents. (Rewriting shall be done upon erasing the all contents.) There is a limit in a number of rewriting.

<p>Trouble shooting 7 INDOOR UNIT Error Method: Manual Auto Switch Error</p>	<p>Indicate or Display: Indoor Unit Operation lamp : 3 time Flash Timer lamp : 5 time Flash ERROR CODE : [E : 35]</p>	<p>Outdoor Unit</p> <table border="1" data-bbox="1119 297 1536 380"> <thead> <tr> <th colspan="6">Monitor</th> </tr> <tr> <th>A</th> <th>B</th> <th>C</th> <th>D</th> <th>E</th> <th>F</th> </tr> </thead> <tbody> <tr> <td>● 5</td> <td>● 15</td> <td>○</td> <td>○</td> <td>○</td> <td>●</td> </tr> </tbody> </table> <p>● : Light ON ○ : Light OFF ● n : n time blinking</p>	Monitor						A	B	C	D	E	F	● 5	● 15	○	○	○	●
Monitor																				
A	B	C	D	E	F															
● 5	● 15	○	○	○	●															

<p>Detective Actuators: Indoor unit controller PCB Indicator PCB Manual auto switch</p>	<p>Detective details: When the Manual Auto Switch becomes ON for consecutive 60 seconds or more.</p>
---	--

Forecast of Cause:
1. Manual Auto Switch failure 2. Controller PCB and Indicator PCB failure

<p>Test 1 : Check the Manual Auto Switch</p>	
<ul style="list-style-type: none"> • Check if Manual Auto Switch is kept pressed. • Check ON/OFF switching operation by using a meter. >> <u>If Manual Auto Switch is disabled (on/off switching), replace it.</u> 	

↓
OK

<p>Test 2 : Replace Controller PCB and Indicator PCB</p>
<p>▶ <u>If Test 1 do not improve the symptom, replace Controller PCB and Indicator PCB.</u></p>

<p>Trouble shooting 8 INDOOR UNIT Error Method: Indoor Room Thermistor Error</p>	<p>Indicate or Display: Indoor Unit Operation lamp : 4 time Flash Timer lamp : 1 time Flash ERROR CODE : [E : 41]</p>	<p>Outdoor Unit</p> <table border="1" style="margin-left: auto; margin-right: auto; border-collapse: collapse;"> <tr> <th colspan="6">Monitor</th> </tr> <tr> <th>A</th> <th>B</th> <th>C</th> <th>D</th> <th>E</th> <th>F</th> </tr> <tr> <td style="text-align: center;">● 5</td> <td style="text-align: center;">● 15</td> <td style="text-align: center;">○</td> <td style="text-align: center;">○</td> <td style="text-align: center;">○</td> <td style="text-align: center;">●</td> </tr> </table> <p style="font-size: small; text-align: center;">● : Light ON ○ : Light OFF ● n : n time blinking</p>	Monitor						A	B	C	D	E	F	● 5	● 15	○	○	○	●
Monitor																				
A	B	C	D	E	F															
● 5	● 15	○	○	○	●															

<p>Detective Actuators: Indoor unit controller PCB circuit Room temperature thermistor</p>	<p>Detective details: Room temperature thermistor is open or short is detected always.</p>
---	--

Forecast of Cause:
 1. Connector failure connection 2. Thermistor failure 3. Controller PCB failure

Test 1 : Check connection of Connector

- Check if connector is loose or removed
- Check erroneous connection
- Check if thermistor cable is open

>>Reset Power when reinstalling due to removed connector or incorrect wiring.

↓ OK

<p>Test 2 : Remove connector and check Thermistor resistance value</p> <p>Thermistor Characteristics (Rough value)</p> <table border="1" style="width: 100%; border-collapse: collapse; font-size: small;"> <tr> <td style="width: 25%;">Temperature (°C)</td> <td style="width: 12.5%;">-10</td> <td style="width: 12.5%;">0</td> <td style="width: 12.5%;">10</td> <td style="width: 12.5%;">20</td> <td style="width: 12.5%;">30</td> <td style="width: 12.5%;">40</td> <td style="width: 12.5%;">45</td> </tr> <tr> <td>Temperature (°F)</td> <td>14</td> <td>32</td> <td>50</td> <td>68</td> <td>86</td> <td>104</td> <td>113</td> </tr> <tr> <td>Resistance Value (kΩ)</td> <td>58.25</td> <td>33.62</td> <td>20.17</td> <td>12.54</td> <td>8.04</td> <td>5.30</td> <td>4.35</td> </tr> </table> <p>▶ If Thermistor is either open or shorted, replace it and reset the power.</p>	Temperature (°C)	-10	0	10	20	30	40	45	Temperature (°F)	14	32	50	68	86	104	113	Resistance Value (kΩ)	58.25	33.62	20.17	12.54	8.04	5.30	4.35	
Temperature (°C)	-10	0	10	20	30	40	45																		
Temperature (°F)	14	32	50	68	86	104	113																		
Resistance Value (kΩ)	58.25	33.62	20.17	12.54	8.04	5.30	4.35																		

↓ OK

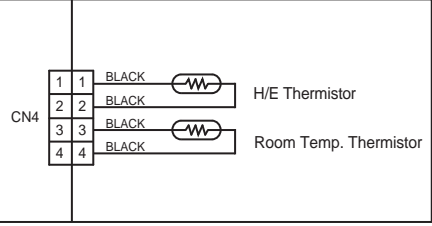
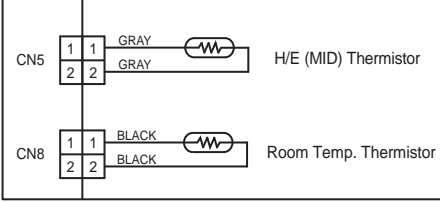
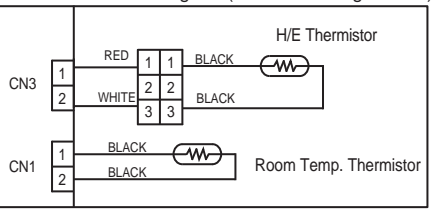
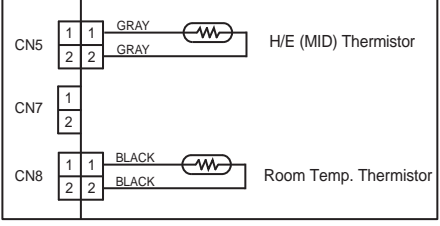
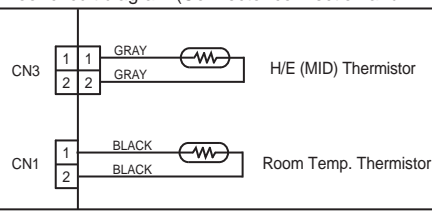
<p>Test 3 : Check voltage of Controller PCB (DC5.0V)</p> <p>Make sure circuit diagram of each indoor unit and check terminal voltage at Thermistor (DC5.0V)</p> <ul style="list-style-type: none"> • Compact wall mount circuit diagram(Connector connection) • Compact cassette circuit diagram (Connector connection) • Wall mount circuit diagram (Direct soldering to PCB) • Slim duct circuit diagram (Connector connection) • Floor circuit diagram (Connector connection and Direct soldering to PCB) <div style="display: flex; justify-content: space-between;"> <div style="width: 48%;">  </div> <div style="width: 48%;">  </div> </div> <div style="display: flex; justify-content: space-between;"> <div style="width: 48%;">  </div> <div style="width: 48%;">  </div> </div> <div style="width: 48%;">  </div>

Trouble shooting 9
INDOOR UNIT Error Method:
Indoor Heat Ex. Thermistor Error

Indicate or Display:
Indoor Unit
Operation lamp : 4 time Flash
Timer lamp : 2 time Flash
ERROR CODE : [E : 42]

Outdoor Unit

Monitor					
A	B	C	D	E	F
● 5	● 15	○	○	○	●

● : Light ON ○ : Light OFF ● n : n time blinking

Detective Actuators:
 Indoor unit controller PCB circuit
 Heat exchanger thermistor

Detective details:
 Heat exchanger thermistor is open or short is detected always.

Forecast of Cause:
 1. Connector failure connection 2. Thermistor failure 3. Controller PCB failure

Test 1 : Check connection of Connector

- Check if connector is loose or removed
- Check erroneous connection
- Check if thermistor cable is open

>>Reset Power when reinstalling due to removed connector or incorrect wiring.



Test 2 : Remove connector and check Thermistor resistance value

Thermistor Characteristics (Rough value)

Temperature (°C)	-30	-20	-10	0	10	20	30	40	50
Temperature (°F)	-22	-4	14	32	50	68	86	104	122
Resistance Value (kΩ)	1131.91	579.59	312.27	176.03	103.34	62.91	39.57	25.64	17.06

Temperature (°C)	60	65
Temperature (°F)	140	149
Resistance Value (kΩ)	11.64	9.69

► If Thermistor is either open or shorted, replace it and reset the power.



Test 3 : Check voltage of Controller PCB (DC5.0V)

Make sure circuit diagram of each indoor unit and check terminal voltage at Thermistor (DC5.0V)

- Compact wall mount circuit diagram (Connector connection)
- Compact cassette circuit diagram (Connector connection)
- Wall mount circuit diagram (Direct soldering to PCB)
- Slim duct circuit diagram (Connector connection)
- Floor circuit diagram (Connector connection and Direct soldering to PCB)

► If the voltage does not appear, replace Controller PCB and execute the check operation again.

Trouble shooting 10 INDOOR UNIT Error Method: Indoor Unit Fan Motor Error	Indicate or Display: Indoor Unit Operation lamp : 5 time Flash Timer lamp : 1 time Flash ERROR CODE : [E : 51]	Outdoor Unit <table border="1" style="margin-left: auto; margin-right: auto;"> <thead> <tr> <th colspan="6">Monitor</th> </tr> <tr> <th>A</th> <th>B</th> <th>C</th> <th>D</th> <th>E</th> <th>F</th> </tr> </thead> <tbody> <tr> <td style="text-align: center;">● 5</td> <td style="text-align: center;">● 15</td> <td style="text-align: center;">○</td> <td style="text-align: center;">○</td> <td style="text-align: center;">○</td> <td style="text-align: center;">●</td> </tr> </tbody> </table> <p style="text-align: center; font-size: small;">● : Light ON ○ : Light OFF ● n : n time blinking</p>	Monitor						A	B	C	D	E	F	● 5	● 15	○	○	○	●
Monitor																				
A	B	C	D	E	F															
● 5	● 15	○	○	○	●															

Detective Actuators: Indoor unit controller PCB Indoor unit fan motor	Detective details: When the condition that actual frequency of indoor fan is below 1/3 of target frequency is continued more than 56 seconds.
--	---

Forecast of Cause: 1. Fan rotation failure 2. Fan motor winding open 3. Motor protection by surrounding temperature rise 4. Control PCB failure 5. Indoor unit fan motor failure
--

Test 1 : Check rotation of Fan
<ul style="list-style-type: none"> · Rotate the fan by hand when operation is off. (Check if fan is caught, dropped off or locked motor) >>If Fan or Bearing is abnormal, replace it.



Test 2 : Check ambient temp. around motor
<ul style="list-style-type: none"> · Check excessively high temperature around the motor. (If there is any surrounding equipment that causes heat) >>Upon the temperature coming down, restart operation.



Test 3 : Check Indoor unit fan motor
<ul style="list-style-type: none"> · Check Indoor unit fan motor. (SERVICE PARTS INFORMATION 5) >>If Indoor unit fan motor is abnormal, replace Indoor unit fan motor.



Test 4 : Replace Controller PCB
<p style="margin-left: 20px;">▶ If Test 1- 3 do not improve the symptom, replace Controller PCB.</p>

Trouble shooting 11 INDOOR UNIT Error Method: Drain Pump Error	Indicate or Display: Indoor Unit Operation lamp : 5 time Flash Timer lamp : 3 time Flash ERROR CODE : [E : 53]	Outdoor Unit <table border="1"> <thead> <tr> <th colspan="6">Monitor</th> </tr> <tr> <th>A</th> <th>B</th> <th>C</th> <th>D</th> <th>E</th> <th>F</th> </tr> </thead> <tbody> <tr> <td>● 5</td> <td>● 15</td> <td>○</td> <td>○</td> <td>○</td> <td>●</td> </tr> </tbody> </table> <p>● : Light ON ○ : Light OFF ● n : n time blinking</p>	Monitor						A	B	C	D	E	F	● 5	● 15	○	○	○	●
Monitor																				
A	B	C	D	E	F															
● 5	● 15	○	○	○	●															

Detective Actuators: Indoor unit controller PCB circuit Float switch	Detective details: When Float switch is ON for more than 3 minutes.
---	---

Forecast of Cause:
 1. Float switch failure 2. Shorted connector/wire 3. Controller PCB failure 4. Drain pump failure 5. Hose clogging

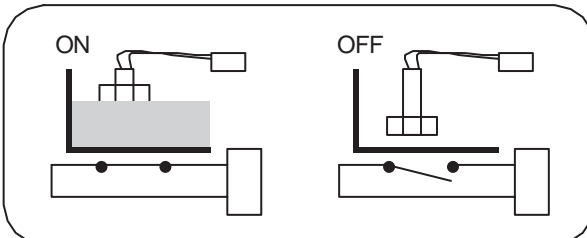
Test 1 : Check Float Switch <input type="checkbox"/> Check operation of float switch. (any blocking by dust, etc.) <input type="checkbox"/> Remove Float switch and check ON/OFF switching operation by using a meter. >> If Float switch is abnormal, replace it.	
---	---

OK

Test 2 : Check Connector (CN 9) / Wire

 Check loose contact of CN9 /shorted wire (pinched wire).
>> Replace Float switch if the wire is abnormal.

OK

Test 3 : Check Drain Hose

 Check Drain Hose .
>> If there is Hose clogging. Please clear the clog.

OK

Test 4 : Check Controller PCB
► If Test 1 - 3 do not improve the symptom, change Controller PCB and execute the check operation again.

Attention!!
 Wall mount / Compact wall mount type does not have a float switch.
 In this case, replace Controller PCB and set up the original address.
 Please refer to.

Trouble shooting 12 INDOOR UNIT Error Method: Damper(OPEN/CLOSE) Detection Limit Switch Error	Indicate or Display: Indoor Unit Operation lamp : 5 time Flash Timer lamp : 7 time Flash ERROR CODE : [E : 57]	Outdoor Unit <table border="1" style="margin-left: auto; margin-right: auto;"> <tr> <th colspan="6">Monitor</th> </tr> <tr> <th>A</th> <th>B</th> <th>C</th> <th>D</th> <th>E</th> <th>F</th> </tr> <tr> <td style="text-align: center;">● 5</td> <td style="text-align: center;">● 15</td> <td style="text-align: center;">○</td> <td style="text-align: center;">○</td> <td style="text-align: center;">○</td> <td style="text-align: center;">●</td> </tr> </table> <p style="text-align: center; font-size: small;">● : Light ON ○ : Light OFF ●n : n time blinking</p>	Monitor						A	B	C	D	E	F	● 5	● 15	○	○	○	●
Monitor																				
A	B	C	D	E	F															
● 5	● 15	○	○	○	●															

Detective Actuators: Indoor unit Controller PCB Circuit Limit switch Damper	Detective details: When limit switch were not able to detect the close though the damper close. (Upper air flow) When limit switch were not able to detect the open though the damper open. (Upper & Lower air flow)
---	---

Forecast of Cause : 1. Limit switch failure 2. Shorted connector/ wire 3. Damper failure 4. Controller PCB failure

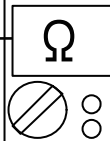
Test 1 : Check Limit switch <ul style="list-style-type: none"> • Check operation of limit switch. (any blocking by dust, etc.) • Remove Limit switch and check ON/OFF switching operation by using a meter. <p>>>If Limit switch is detective, replace it.</p>	
---	---

↓
OK

Test 2 : Check Connector (CN18) / Wire <ul style="list-style-type: none"> • Check loose contact of CN18 /shorted wire (pinched wire). <p>>>Replace Limit switch if the wire is abnormal</p>

↓
OK

Test 3 : Check Damper <ul style="list-style-type: none"> • Check the obstruction of damper movement. • Check the damper movement. <p>>>Replace Damper if the damper is abnormal</p>
--

↓
OK

Test 4 : Replace Controller PCB <p>▶ If Check Point 1~3 do not improve the symptom, change Controller PCB.</p>

Trouble shooting 13 INDOOR UNIT Error Method: Damper(OPEN/CLOSE) Simultaneous Detection Limit Switch Error	Indicate or Display: Indoor Unit Operation lamp : 5 time Flash Timer lamp : 7 time Flash ERROR CODE : [E : 57]	Outdoor Unit <table border="1" style="margin-left: auto; margin-right: auto;"> <thead> <tr> <th colspan="6">Monitor</th> </tr> <tr> <th>A</th> <th>B</th> <th>C</th> <th>D</th> <th>E</th> <th>F</th> </tr> </thead> <tbody> <tr> <td style="text-align: center;">● 5</td> <td style="text-align: center;">● 15</td> <td style="text-align: center;">○</td> <td style="text-align: center;">○</td> <td style="text-align: center;">○</td> <td style="text-align: center;">●</td> </tr> </tbody> </table> <p style="text-align: center; font-size: small;">● : Light ON ○ : Light OFF ● n : n time blinking</p>	Monitor						A	B	C	D	E	F	● 5	● 15	○	○	○	●
Monitor																				
A	B	C	D	E	F															
● 5	● 15	○	○	○	●															

Detective Actuators: Indoor unit Controller PCB Circuit Limit switch	Detective details: When the limit switch detects open and close at the simultaneous.
---	--

Forecast of Cause :

1. Limit switch failure 2. Shorted connector/ wire 3. Controller PCB failure

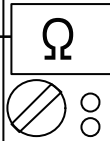
Check Point 1 : Check Limit switch <ul style="list-style-type: none"> · Check operation of limit switch. (any blocking by dust, etc.) · Remove Limit switch and check ON/OFF switching operation by using a meter. <p>>>If Limit switch is detective, replace it.</p>	
--	---



Check Point 2 : Check Connector (CN18) / Wire
<ul style="list-style-type: none"> · Check loose contact of CN18 /shorted wire (pinched wire). <p>>>Replace Limit switch if the wire is abnormal</p>



Check Point 3 : Replace Controller PCB
<p>▶ If Check Point 1 & 2 do not improve the symptom, change Controller PCB.</p>

Trouble shooting 14 INDOOR UNIT Error Method: Intake Grille Error	Indicate or Display: Indoor Unit Operation lamp : 5 time Flash Timer lamp : 8 time Flash ERROR CODE : [E : 58]	Outdoor Unit <table border="1" style="margin-left: auto; margin-right: auto;"> <thead> <tr> <th colspan="6">Monitor</th> </tr> <tr> <th>A</th> <th>B</th> <th>C</th> <th>D</th> <th>E</th> <th>F</th> </tr> </thead> <tbody> <tr> <td style="text-align: center;">● 5</td> <td style="text-align: center;">● 15</td> <td style="text-align: center;">○</td> <td style="text-align: center;">○</td> <td style="text-align: center;">○</td> <td style="text-align: center;">●</td> </tr> </tbody> </table> <p style="text-align: center; font-size: small;">● : Light ON ○ : Light OFF ● n : n time blinking</p>	Monitor						A	B	C	D	E	F	● 5	● 15	○	○	○	●
Monitor																				
A	B	C	D	E	F															
● 5	● 15	○	○	○	●															

Detective Actuators: Indoor unit controller PCB Micro switch	Detective details: When the Micro switch detected open while running the compressor.
---	--

Forecast of Cause:
 1. Micro switch failure 2. Shorted connector/ wire 3. Controller PCB failure

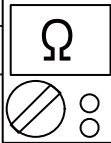
Test 1 : Check Limit switch <ul style="list-style-type: none"> · Check operation of Micro switch. (any blocking by dust, etc.) · Remove Micro switch and check ON/OFF switching operation by using a meter. <p>>>If Micro switch is detective, replace it.</p>	
---	---

↓
OK

Test 2 : Check Connector (CN11) / Wire <ul style="list-style-type: none"> · Check loose contact of CN11 /shorted wire (pinched wire). <p>>>Replace Micro switch if the wire is abnormal</p>

↓
OK

Test 3 : Replace Controller PCB <p>▶ If Test 1 - 2 do not improve the symptom, change Controller PCB.</p>
--

Trouble shooting 15 OUTDOOR UNIT Error Method: Outdoor Unit Model Information Error	Indicate or Display: Indoor Unit Operation lamp : 6 time Flash Timer lamp : 2 time Flash ERROR CODE : [E : 62]	Outdoor Unit <table border="1"> <thead> <tr> <th colspan="6">Monitor</th> </tr> <tr> <th>A</th> <th>B</th> <th>C</th> <th>D</th> <th>E</th> <th>F</th> </tr> </thead> <tbody> <tr> <td>● 6</td> <td>● 2</td> <td>○</td> <td>○</td> <td>○</td> <td>●</td> </tr> </tbody> </table> <p>● : Light ON ○ : Light OFF ●n : n time blinking</p>	Monitor						A	B	C	D	E	F	● 6	● 2	○	○	○	●
	Monitor																			
A	B	C	D	E	F															
● 6	● 2	○	○	○	●															

Detective Actuators: Outdoor unit main PCB	Detective details: When power is on and there is some below case. ① When model information of EEPROM is incorrect. ② When the access to EEPROM failed.
--	--

Forecast of Cause:
 1. External cause 2. Defective connection of electric components 3. Main PCB failure

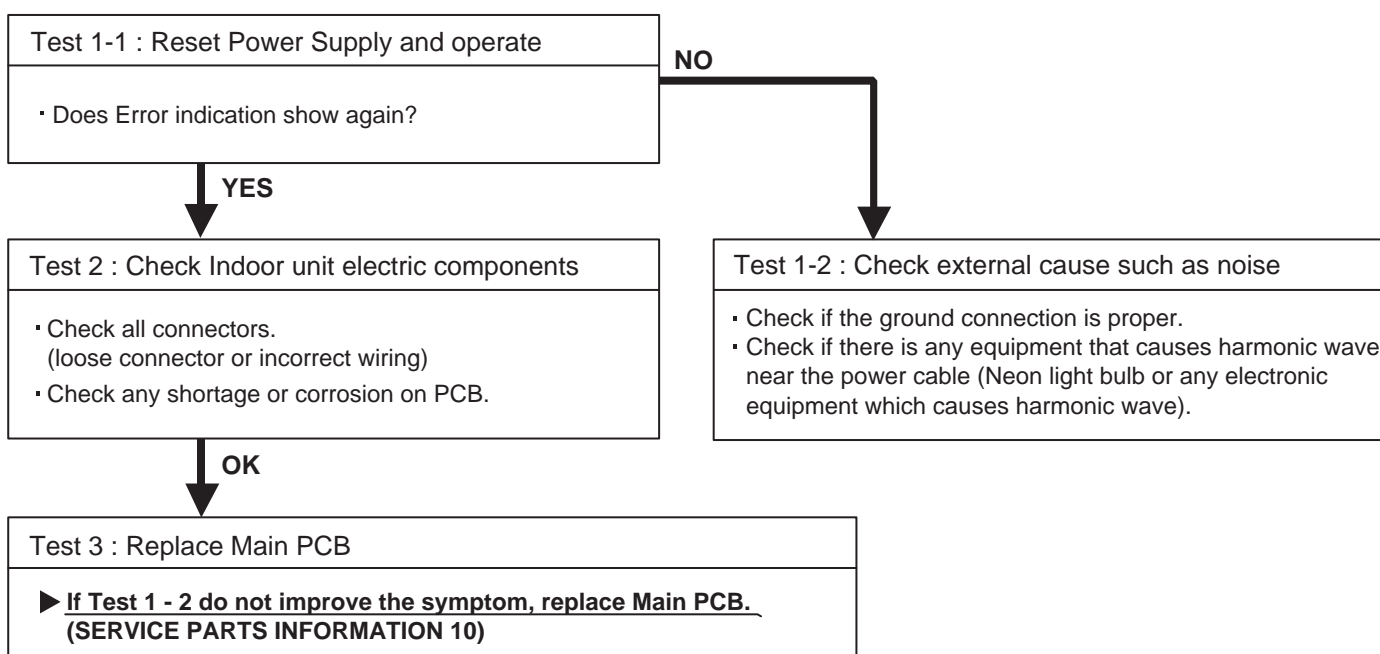

Note : EEPROM

EEPROM(Electronically Erasable and Programmable Read Only Memory) is a non-volatile memory which keeps memorized information even if power is turned off. It can change the contents electronically. To change the contents, it uses higher voltage than normal, and it can not change a partial contents. (Rewriting shall be done upon erasing the all contents.) There is a limit in a number of rewriting.

Trouble shooting 16 OUTDOOR UNIT Error Method: EEPROM Access Error	Indicate or Display: Indoor Unit Operation lamp : - time Flash Timer lamp : - time Flash ERROR CODE : [E : --]	Outdoor Unit <table border="1" style="margin-left: auto; margin-right: auto;"> <tr> <th colspan="6">Monitor</th> </tr> <tr> <th>A</th> <th>B</th> <th>C</th> <th>D</th> <th>E</th> <th>F</th> </tr> <tr> <td style="text-align: center;">● 6</td> <td style="text-align: center;">● 2</td> <td style="text-align: center;">○</td> <td style="text-align: center;">○</td> <td style="text-align: center;">●</td> <td style="text-align: center;">●</td> </tr> </table> <p style="text-align: center; font-size: small;">● : Light ON ○ : Light OFF ●n : n time blinking</p>	Monitor						A	B	C	D	E	F	● 6	● 2	○	○	●	●
Monitor																				
A	B	C	D	E	F															
● 6	● 2	○	○	●	●															

Detective Actuators: Outdoor unit Main PCB	Detective details: When the check run if can not write data to the EEPROM.
--	--

Forecast of Cause: 1. External cause 2. Main PCB defective

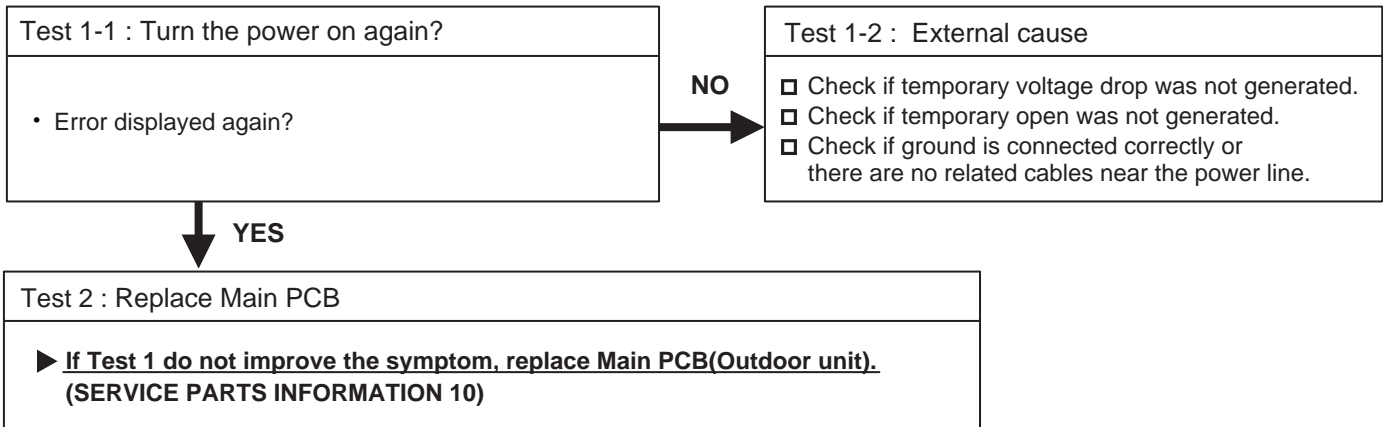

<p>Trouble shooting 17 OUTDOOR UNIT Error Method: Inverters Communication Error</p>	<p>Indicate or Display: Indoor Unit Operation lamp : 6 time Flash Timer lamp : 2 time Flash ERROR CODE : [E : 62]</p>	<p>Outdoor Unit</p> <table border="1" data-bbox="1102 288 1512 369"> <thead> <tr> <th colspan="6">Monitor</th> </tr> <tr> <th>A</th> <th>B</th> <th>C</th> <th>D</th> <th>E</th> <th>F</th> </tr> </thead> <tbody> <tr> <td>● 6</td> <td>● 2</td> <td>○</td> <td>●</td> <td>●</td> <td>○</td> </tr> </tbody> </table> <p>● : Light ON ○ : Light OFF ●n : n time blinking</p>	Monitor						A	B	C	D	E	F	● 6	● 2	○	●	●	○
Monitor																				
A	B	C	D	E	F															
● 6	● 2	○	●	●	○															

<p>Detective Actuators: Outdoor unit Main PCB</p>	<p>Detective details: Communication not received from Inverter PCB for 10 seconds more</p>
---	--

Forecast of Cause: 1. Noise 2. Main PCB to Inverter PCB wiring connection defective
3. Main PCB defective 4. Inverter PCB defective

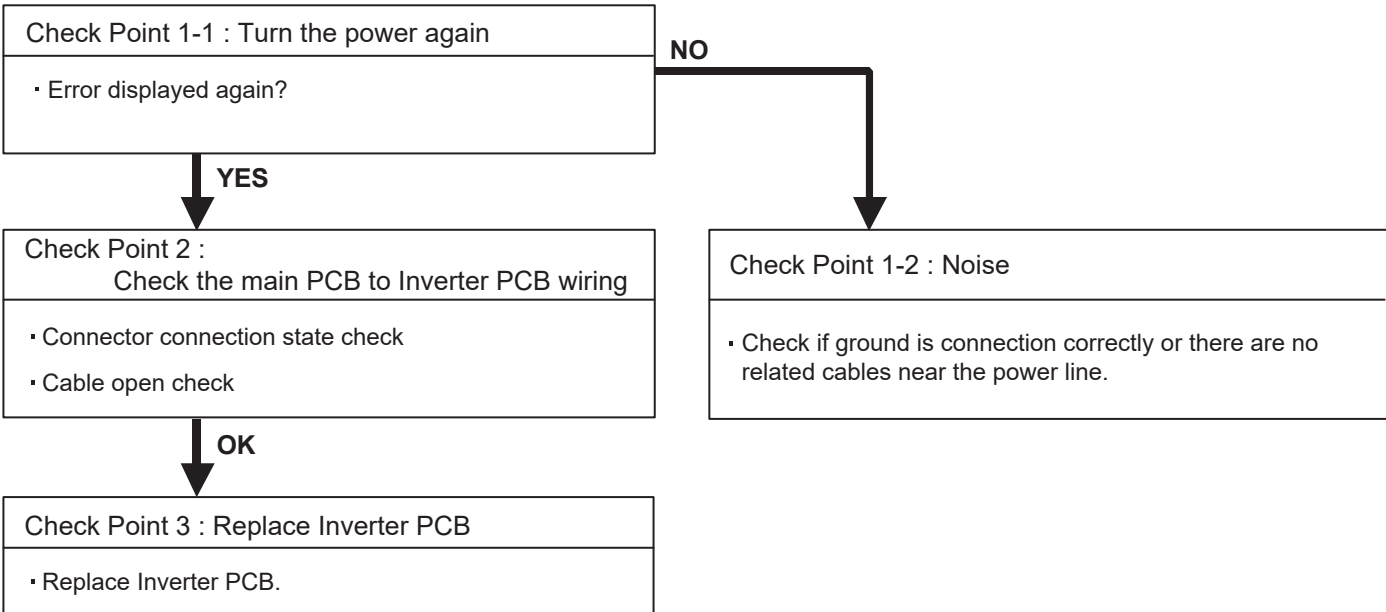

Trouble shooting 18 OUTDOOR UNIT Error Method: EEPROM Data Corruption Error	Indicate or Display: Indoor Unit Operation lamp : - time Flash Timer lamp : - time Flash ERROR CODE : [E : --]	Outdoor Unit <table border="1" data-bbox="1205 394 1614 479"> <thead> <tr> <th colspan="6">Monitor</th> </tr> <tr> <th>A</th> <th>B</th> <th>C</th> <th>D</th> <th>E</th> <th>F</th> </tr> </thead> <tbody> <tr> <td>● 6</td> <td>● 2</td> <td>●</td> <td>○</td> <td>○</td> <td>○</td> </tr> </tbody> </table> <p>● : Light ON ○ : Light OFF ● n : n time blinking</p>	Monitor						A	B	C	D	E	F	● 6	● 2	●	○	○	○
Monitor																				
A	B	C	D	E	F															
● 6	● 2	●	○	○	○															

Detective Actuators: Outdoor unit Main PCB	Detective details: When the power is turned on and When the data of the automatic correction was damaged
--	---

Forecast of Cause: 1. External cause 2. Main PCB defective

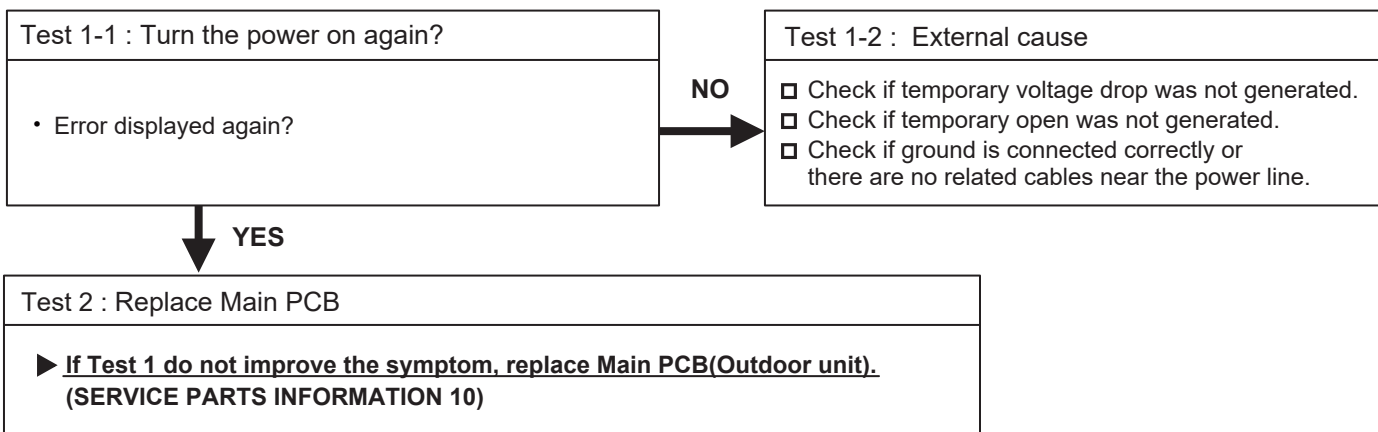

Trouble shooting 19 OUTDOOR UNIT Error Method: Inverter Error	Indicate or Display: Indoor Unit Operation lamp : 6 time Flash Timer lamp : 3 time Flash ERROR CODE : [E : 63]	Outdoor Unit <table border="1"> <thead> <tr> <th colspan="6">Monitor</th> </tr> <tr> <th>A</th> <th>B</th> <th>C</th> <th>D</th> <th>E</th> <th>F</th> </tr> </thead> <tbody> <tr> <td>● 6</td> <td>● 3</td> <td>○</td> <td>○</td> <td>○</td> <td>●</td> </tr> </tbody> </table> ● : Light ON ○ : Light OFF ● n : n time blinking	Monitor						A	B	C	D	E	F	● 6	● 3	○	○	○	●
	Monitor																			
A	B	C	D	E	F															
● 6	● 3	○	○	○	●															
Detective Actuators: Inverter PCB	Detective details: Error information received from Inverter PCB																			

Forecast of Cause:

1. External cause
2. Power supply to Filter PCB to Inverter PCB wiring disconnection, open
3. Filter PCB failure
4. Inverter PCB failure

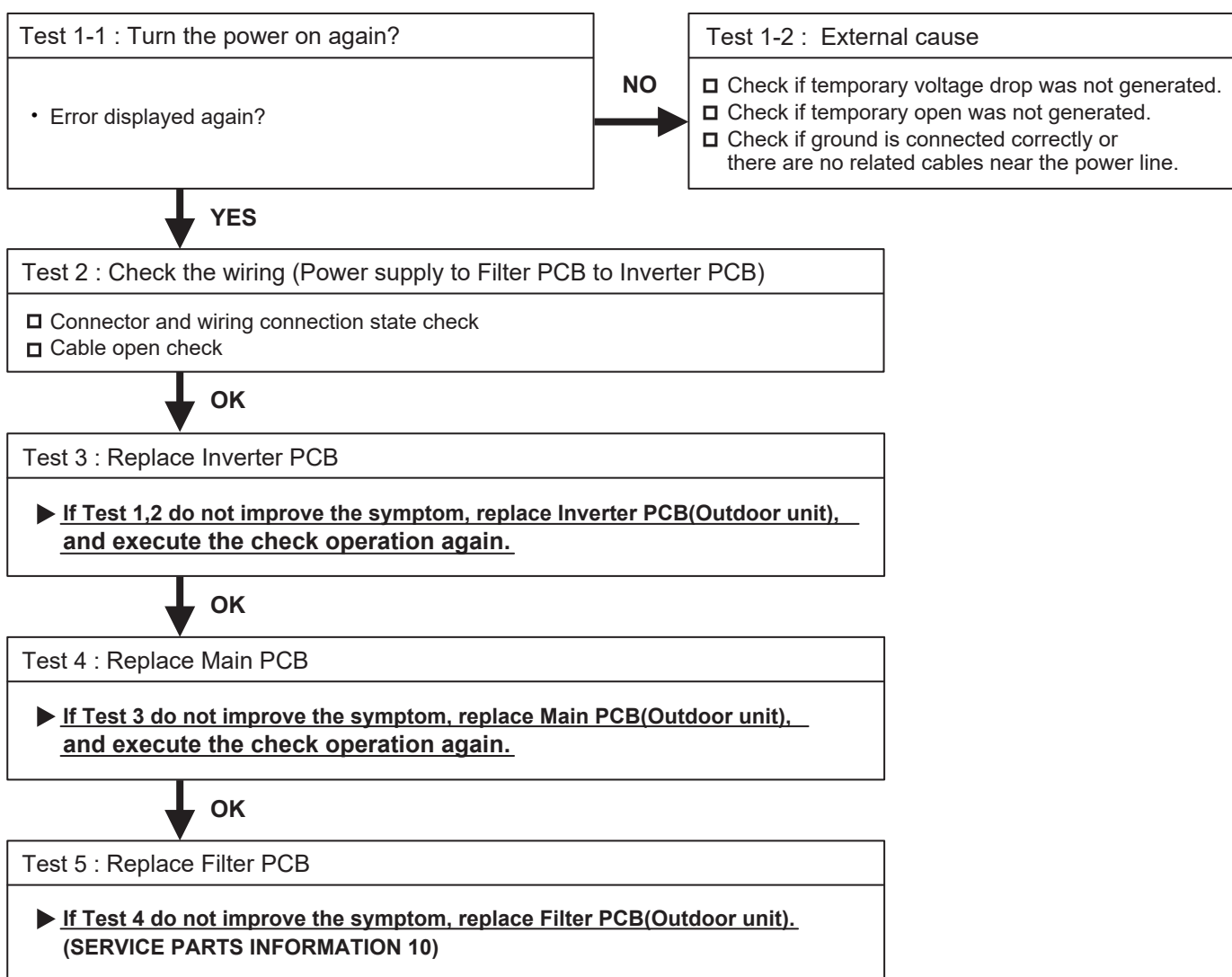

Trouble shooting 20 <u>OUTDOOR UNIT Error Method:</u> Active Filter Error	<u>Indicate or Display:</u>	
	Indoor Unit Operation lamp : 6 time Flash Timer lamp : 4 time Flash ERROR CODE : [E : 64]	Outdoor Unit No Display

<u>Detective Actuators:</u> Outdoor unit main PCB Active filter module	<u>Detective details:</u> ① When inverter input DC voltage is higher than 430V or lower than 110V. ② When a momentary power cut off occurred on low voltage.
---	---

<u>Forecast of Cause:</u> 1. External cause 2. Connector connection failure 3. Main PCB failure 4. Active filter module failure

Test 1 : Check external cause at Indoor and Outdoor (Voltage drop or Noise)
<ul style="list-style-type: none"> • Instant drop : Check if there is a large load electric apparatus in the same circuit. • Momentary power failure : Check if there is a defective contact or leak current in the power supply circuit. • Noise : Check if there is any equipment causing harmonic wave near electric line. (Neon bulb or electric equipment that may cause harmonic wave) Check the complete insulation of grounding.

↓
OK

Test 2 : Check connection of Connector
<ul style="list-style-type: none"> • Check if connector is removed. • Check erroneous connection. • Check if cable is open. <p>>><u>Upon correcting the removed connector or miss-swiring, reset the power.</u></p>

↓
OK

Test 3 : Check Active filter module
<ul style="list-style-type: none"> • Check Active filter module. (SERVICE PARTS INFORMATION 8) <p>>><u>If Active filter module is abnormal, replace it.</u></p>

↓
OK

Test 4 : Replace Main PCB
<p>▶ <u>If Test 1 - 3 do not improve the symptom, replace Main PCB.</u> (SERVICE PARTS INFORMATION 10)</p>

Trouble shooting 21 OUTDOOR UNIT Error Method: IPM Error	Indicate or Display: Indoor Unit Operation lamp : 6 time Flash Timer lamp : 5 time Flash ERROR CODE : [E : 65]	Outdoor Unit <table border="1"> <thead> <tr> <th colspan="6">Monitor</th> </tr> <tr> <th>A</th> <th>B</th> <th>C</th> <th>D</th> <th>E</th> <th>F</th> </tr> </thead> <tbody> <tr> <td>● 6</td> <td>● 5</td> <td>○</td> <td>○</td> <td>●</td> <td>●</td> </tr> </tbody> </table> <p>● : Light ON ○ : Light OFF ● n : n time blinking</p>	Monitor						A	B	C	D	E	F	● 6	● 5	○	○	●	●
	Monitor																			
A	B	C	D	E	F															
● 6	● 5	○	○	●	●															

Detective Actuators: Outdoor unit main PCB Outdoor fan motor Compressor	Detective details: ① When more than normal operating current to IPM in Main PCB flows, the compressor stops. ② After the compressor restarts, if the same operation is repeated within 40 sec, the compressor stops again. ③ If ① and ② repeats 5 times, the compressor stops permanently.
---	--

Forecast of Cause:

1. Defective connection of electric components	2. Outdoor Fan Operation failure	5. Main PCB failure
3. Outdoor Heat Exchanger clogged	4. Compressor failure	

Test 1 : Check connections of Outdoor Unit Electrical Components

- Check if the terminal connection is loose.
- Check if connector is removed.
- Check erroneous connection.
- Check if cable is open.

>> **Upon correcting the removed connector or miss-wiring, reset the power.**

↓ OK

Test 2 : Check Outdoor Fan, Heat Exchanger

- Is there anything obstructing the air distribution circuit?
- Is there any clogging of Outdoor Heat Exchanger?
- Is the Fan rotating by hand when operation is off?

>> **If the Fan Motor is locked, replace it.**

↓ OK

Test 3 : Check Outdoor Fan

- Check Outdoor Fan Motor. (Refer to Trouble shooting 32)

>> **If the Fan Motor is failure, replace it.**

↓ OK

Test 4 : Check Compressor

- Check Compressor. (SERVICE PARTS INFORMATION 2)

↓ OK

Test 5 : Replace Main PCB

▶ **If Test 1 - 4 do not improve the symptom, replace Main PCB. (SERVICE PARTS INFORMATION 10)**

Trouble shooting 22 OUTDOOR UNIT Error Method: Discharge Thermister Error	Indicate or Display: Indoor Unit Operation lamp : 7 time Flash Timer lamp : 1 time Flash ERROR CODE : [E : 71]	Outdoor Unit <table border="1" style="width: 100%; border-collapse: collapse; text-align: center;"> <tr> <th colspan="6">Monitor</th> </tr> <tr> <th>A</th> <th>B</th> <th>C</th> <th>D</th> <th>E</th> <th>F</th> </tr> <tr> <td>● 7</td> <td>● 1</td> <td>○</td> <td>○</td> <td>○</td> <td>●</td> </tr> </table> <p>● : Light ON ○ : Light OFF ●n : n time blinking</p>	Monitor						A	B	C	D	E	F	● 7	● 1	○	○	○	●
Monitor																				
A	B	C	D	E	F															
● 7	● 1	○	○	○	●															

Detective Actuators: Outdoor unit main PCB circuit Discharge pipe temperature thermistor	Detective details: When Discharge pipe temperature thermistor open or short-circuit is detected at power ON or while running the compressor.
---	--

Forecast of Cause:
 1. Connector connection failure 2. Thermistor failure 3. Main PCB failure

Test 1 : Check connection of Connector

- Check if connector is removed.
- Check erroneous connection.
- Check if thermistor cable is open.

>>Upon correcting the removed connector or miss-wiring, reset the power.



Test 2 : Remove connector and check Thermistor resistance value

Ω

Thermistor Characteristics (Approx. value)

Temperature (°C)	-30	-20	-10	0	10	20	30	40	50
Temperature (°F)	-22	-4	14	32	50	68	86	104	122
Resistance Value (k Ω)	1013.11	531.56	292.91	168.60	100.91	62.55	40.01	26.34	17.79

Temperature (°C)	60	70	80	90	100	110	120
Temperature (°F)	140	158	176	194	212	230	248
Resistance Value (k Ω)	12.30	8.70	6.27	4.60	3.43	2.60	2.00

► If Thermistor is either open or shorted, replace it and reset the power.



Test 3 : Check voltage of Main PCB (DC5.0V)

DC

Make sure circuit diagram of outdoor unit and check terminal voltage at Thermistor (DC5.0V)

CN61	1 1	BLACK							
	2 2	BLACK							
	3 3	BLACK							
				THERMISTOR					
									(OUTDOOR TEMP.)
CN62	1 1	BLACK							
	2 2	BLACK							
	3 3	BLACK							
				THERMISTOR					
									(HEX OUT TEMP.)
CN63	1 1	BLACK							
	2 2	BLACK							
	3 3	BLACK							
	4 4	BLACK							
				THERMISTOR					
									(DISCHARGE TEMP.)
				THERMISTOR					
									(COMP TEMP.)

► If the voltage does not appear, replace Main PCB.

Trouble shooting 23 OUTDOOR UNIT Error Method: Compressor Thermister Error	Indicate or Display: Indoor Unit Operation lamp : 7 time Flash Timer lamp : 2 time Flash ERROR CODE : [E : 72]	Outdoor Unit <table border="1" style="width: 100%; border-collapse: collapse; text-align: center;"> <tr> <th colspan="6">Monitor</th> </tr> <tr> <th>A</th> <th>B</th> <th>C</th> <th>D</th> <th>E</th> <th>F</th> </tr> <tr> <td>● 7</td> <td>● 2</td> <td>○</td> <td>○</td> <td>○</td> <td>●</td> </tr> </table> <p>● : Light ON ○ : Light OFF ●n : n time blinking</p>	Monitor						A	B	C	D	E	F	● 7	● 2	○	○	○	●
Monitor																				
A	B	C	D	E	F															
● 7	● 2	○	○	○	●															

Detective Actuators: Outdoor unit main PCB circuit Compressor temperature thermistor	Detective details: When Compressor temperature thermistor open or short-circuit is detected at power ON or while running the compressor.
---	--

Forecast of Cause:
 1. Connector connection failure 2. Thermistor failure 3. Main PCB failure

Test 1 : Check connection of Connector

- Check if connector is removed.
- Check erroneous connection.
- Check if thermistor cable is open.

>>Upon correcting the removed connector or miss-wiring, reset the power.



Test 2 : Remove connector and check Thermistor resistance value

Ω

Thermistor Characteristics (Rough value)

Temperature (°C)	-30	-20	-10	0	10	20	30	40	50
Temperature (°F)	-22	-4	14	32	50	68	86	104	122
Resistance Value (k Ω)	1013.11	531.56	292.91	168.60	100.91	62.55	40.01	26.34	17.79

Temperature (°C)	60	70	80	90	100	110	120
Temperature (°F)	140	158	176	194	212	230	248
Resistance Value (k Ω)	12.30	8.70	6.27	4.60	3.43	2.60	2.00

► If Thermistor is either open or shorted, replace it and reset the power.



Test 3 : Check voltage of Main PCB (DC5.0V)

DC

Make sure circuit diagram of outdoor unit and check terminal voltage at Thermistor (DC5.0V)

CN61	1 1	BLACK		THERMISTOR	(OUTDOOR TEMP.)
	2 2	BLACK			
	3 3	BLACK			
CN62	1 1	BLACK		THERMISTOR	(HEX OUT TEMP.)
	2 2	BLACK			
	3 3	BLACK			
CN63	1 1	BLACK		THERMISTOR	(DISCHARGE TEMP.)
	2 2	BLACK			
	3 3	BLACK		THERMISTOR	(COMP TEMP.)
	4 4	BLACK			

► If the voltage does not appear, replace Main PCB.

<p>Trouble shooting 24 OUTDOOR UNIT Error Method: Heat Ex. OUT Thermistor Error</p>	<p>Indicate or Display: Indoor Unit Operation lamp : 7 time Flash Timer lamp : 3 time Flash ERROR CODE : [E : 73]</p>	<p>Outdoor Unit</p> <table border="1" style="margin-left: auto; margin-right: auto; border-collapse: collapse;"> <tr> <th colspan="6">Monitor</th> </tr> <tr> <th>A</th> <th>B</th> <th>C</th> <th>D</th> <th>E</th> <th>F</th> </tr> <tr> <td style="text-align: center;">● 7</td> <td style="text-align: center;">● 3</td> <td style="text-align: center;">○</td> <td style="text-align: center;">○</td> <td style="text-align: center;">●</td> <td style="text-align: center;">●</td> </tr> </table> <p style="font-size: small; text-align: center;">● : Light ON ○ : Light OFF ●n : n time blinking</p>	Monitor						A	B	C	D	E	F	● 7	● 3	○	○	●	●
Monitor																				
A	B	C	D	E	F															
● 7	● 3	○	○	●	●															

<p>Detective Actuators: Outdoor unit main PCB circuit Heat Ex. temperature thermistor</p>	<p>Detective details: When Heat Ex. temperature thermistor open or short-circuit is detected at power ON or while running the compressor.</p>
--	---

Forecast of Cause:
 1. Connector connection failure 2. Thermistor failure 3. Main PCB failure

Test 1 : Check connection of Connector

- Check if connector is removed.
- Check erroneous connection.
- Check if thermistor cable is open.

>>Upon correcting the removed connector or miss-wiring, reset the power.



<p>Test 2 : Remove connector and check Thermistor resistance value</p> <p>Thermistor Characteristics (Approx. value)</p> <table border="1" style="width: 100%; border-collapse: collapse; font-size: small;"> <tr> <td style="width: 20%;">Temperature (°C)</td> <td style="width: 10%;">-30</td> <td style="width: 10%;">-20</td> <td style="width: 10%;">-10</td> <td style="width: 10%;">0</td> <td style="width: 10%;">10</td> <td style="width: 10%;">20</td> <td style="width: 10%;">30</td> <td style="width: 10%;">40</td> <td style="width: 10%;">50</td> </tr> <tr> <td>Temperature (°F)</td> <td>-22</td> <td>-4</td> <td>14</td> <td>32</td> <td>50</td> <td>68</td> <td>86</td> <td>104</td> <td>122</td> </tr> <tr> <td>Resistance Value (kΩ)</td> <td>95.58</td> <td>50.31</td> <td>27.81</td> <td>16.05</td> <td>9.63</td> <td>5.98</td> <td>3.84</td> <td>2.53</td> <td>1.71</td> </tr> </table> <table border="1" style="width: 100%; border-collapse: collapse; font-size: small; margin-top: 5px;"> <tr> <td style="width: 20%;">Temperature (°C)</td> <td style="width: 10%;">60</td> <td style="width: 10%;">70</td> <td style="width: 10%;">80</td> </tr> <tr> <td>Temperature (°F)</td> <td>140</td> <td>158</td> <td>176</td> </tr> <tr> <td>Resistance Value (kΩ)</td> <td>1.19</td> <td>0.84</td> <td>0.61</td> </tr> </table> <p>►If Thermistor is either open or shorted, replace it and reset the power.</p>	Temperature (°C)	-30	-20	-10	0	10	20	30	40	50	Temperature (°F)	-22	-4	14	32	50	68	86	104	122	Resistance Value (kΩ)	95.58	50.31	27.81	16.05	9.63	5.98	3.84	2.53	1.71	Temperature (°C)	60	70	80	Temperature (°F)	140	158	176	Resistance Value (kΩ)	1.19	0.84	0.61	
Temperature (°C)	-30	-20	-10	0	10	20	30	40	50																																		
Temperature (°F)	-22	-4	14	32	50	68	86	104	122																																		
Resistance Value (kΩ)	95.58	50.31	27.81	16.05	9.63	5.98	3.84	2.53	1.71																																		
Temperature (°C)	60	70	80																																								
Temperature (°F)	140	158	176																																								
Resistance Value (kΩ)	1.19	0.84	0.61																																								



<p>Test 3 : Check voltage of Main PCB (DC5.0V)</p> <p>Make sure circuit diagram of outdoor unit and check terminal voltage at Thermistor (DC5.0V)</p> <div style="border: 1px solid black; padding: 5px; margin: 10px 0;"> <table style="width: 100%; border-collapse: collapse; font-size: small;"> <tr> <td style="width: 15%; vertical-align: top;">CN61</td> <td style="width: 10%; text-align: center;">1 1</td> <td style="width: 15%;">BLACK</td> <td style="width: 15%; text-align: center;">(Thermistor symbol)</td> <td style="width: 45%;">THERMISTOR (OUTDOOR TEMP.)</td> </tr> <tr> <td></td> <td style="text-align: center;">2 2</td> <td>BLACK</td> <td></td> <td></td> </tr> <tr> <td></td> <td style="text-align: center;">3 3</td> <td>BLACK</td> <td></td> <td></td> </tr> <tr> <td style="vertical-align: top;">CN62</td> <td style="text-align: center;">1 1</td> <td>BLACK</td> <td style="text-align: center;">(Thermistor symbol)</td> <td>THERMISTOR (HEX OUT TEMP.)</td> </tr> <tr> <td></td> <td style="text-align: center;">2 2</td> <td>BLACK</td> <td></td> <td></td> </tr> <tr> <td></td> <td style="text-align: center;">3 3</td> <td>BLACK</td> <td></td> <td></td> </tr> <tr> <td style="vertical-align: top;">CN63</td> <td style="text-align: center;">1 1</td> <td>BLACK</td> <td style="text-align: center;">(Thermistor symbol)</td> <td>THERMISTOR (DISCHARGE TEMP.)</td> </tr> <tr> <td></td> <td style="text-align: center;">2 2</td> <td>BLACK</td> <td></td> <td></td> </tr> <tr> <td></td> <td style="text-align: center;">3 3</td> <td>BLACK</td> <td style="text-align: center;">(Thermistor symbol)</td> <td>THERMISTOR (COMP TEMP.)</td> </tr> <tr> <td></td> <td style="text-align: center;">4 4</td> <td>BLACK</td> <td></td> <td></td> </tr> </table> </div> <p>► If the voltage does not appear, replace Main PCB.</p>	CN61	1 1	BLACK	(Thermistor symbol)	THERMISTOR (OUTDOOR TEMP.)		2 2	BLACK				3 3	BLACK			CN62	1 1	BLACK	(Thermistor symbol)	THERMISTOR (HEX OUT TEMP.)		2 2	BLACK				3 3	BLACK			CN63	1 1	BLACK	(Thermistor symbol)	THERMISTOR (DISCHARGE TEMP.)		2 2	BLACK				3 3	BLACK	(Thermistor symbol)	THERMISTOR (COMP TEMP.)		4 4	BLACK			
CN61	1 1	BLACK	(Thermistor symbol)	THERMISTOR (OUTDOOR TEMP.)																																															
	2 2	BLACK																																																	
	3 3	BLACK																																																	
CN62	1 1	BLACK	(Thermistor symbol)	THERMISTOR (HEX OUT TEMP.)																																															
	2 2	BLACK																																																	
	3 3	BLACK																																																	
CN63	1 1	BLACK	(Thermistor symbol)	THERMISTOR (DISCHARGE TEMP.)																																															
	2 2	BLACK																																																	
	3 3	BLACK	(Thermistor symbol)	THERMISTOR (COMP TEMP.)																																															
	4 4	BLACK																																																	

<p>Trouble shooting 25 OUTDOOR UNIT Error Method: Outdoor Thermistor Error</p>	<p>Indicate or Display: Indoor Unit Operation lamp : 7 time Flash Timer lamp : 4 time Flash ERROR CODE : [E : 74]</p>	<p>Outdoor Unit</p> <table border="1" style="width: 100%; border-collapse: collapse; text-align: center;"> <tr> <th colspan="6">Monitor</th> </tr> <tr> <th>A</th> <th>B</th> <th>C</th> <th>D</th> <th>E</th> <th>F</th> </tr> <tr> <td>● 7</td> <td>● 4</td> <td>○</td> <td>○</td> <td>○</td> <td>●</td> </tr> </table> <p>● : Light ON ○ : Light OFF ●n : n time blinking</p>	Monitor						A	B	C	D	E	F	● 7	● 4	○	○	○	●
Monitor																				
A	B	C	D	E	F															
● 7	● 4	○	○	○	●															

<p>Detective Actuators: Outdoor unit main PCB circuit Outdoor temperature thermistor</p>	<p>Detective details: When Outdoor temperature thermistor open or short-circuit is detected at power ON or while running the compressor.</p>
---	--

Forecast of Cause:
 1. Connector connection failure 2. Thermistor failure 3. Main PCB failure

Test 1 : Check connection of Connector

- Check if connector is removed.
- Check erroneous connection.
- Check if thermistor cable is open.

>>Upon correcting the removed connector or miss-wiring, reset the power.



Test 2 : Remove connector and check Thermistor resistance value

Thermistor Characteristics (Approx. value)

Temperature (°C)	-30	-20	-10	0	10	20	30	40	50
Temperature (°F)	-22	-4	14	32	50	68	86	104	122
Resistance Value (kΩ)	224.33	115.24	62.28	35.21	20.72	12.64	7.97	5.18	3.45

Temperature (°C)	60	70	80
Temperature (°F)	140	158	176
Resistance Value (kΩ)	2.36	1.65	1.18

► **If Thermistor is either open or shorted, replace it and reset the power.**



Test 3 : Check voltage of Main PCB (DC5.0V)

Make sure circuit diagram of outdoor unit and check terminal voltage at Thermistor (DC5.0V)

CN61	1 1 2 2 3 3	BLACK BLACK BLACK		THERMISTOR (OUTDOOR TEMP.)
CN62	1 1 2 2 3 3	BLACK BLACK BLACK		THERMISTOR (HEX OUT TEMP.)
CN63	1 1 2 2 3 3 4 4	BLACK BLACK BLACK BLACK	 	THERMISTOR (DISCHARGE TEMP.) THERMISTOR (COMP TEMP.)

► **If the voltage does not appear, replace Main PCB.**

<p>Trouble shooting 26 OUTDOOR UNIT Error Method: 2-Way Valve Thermistor Error</p>	<p>Indicate or Display: Indoor Unit Operation lamp : 7 time Flash Timer lamp : 6 time Flash ERROR CODE : [E : 76]</p>	<p>Outdoor Unit</p> <table border="1" style="width: 100%; border-collapse: collapse; text-align: center;"> <tr> <th colspan="6">Monitor</th> </tr> <tr> <th>A</th> <th>B</th> <th>C</th> <th>D</th> <th>E</th> <th>F</th> </tr> <tr> <td>● 7</td> <td>● 6</td> <td>○</td> <td>○</td> <td>○</td> <td>●</td> </tr> </table> <p>● : Light ON ○ : Light OFF ●n : n time blinking</p>	Monitor						A	B	C	D	E	F	● 7	● 6	○	○	○	●
Monitor																				
A	B	C	D	E	F															
● 7	● 6	○	○	○	●															

<p>Detective Actuators: Outdoor unit main PCB circuit 2 Way valve temperature thermistor</p>	<p>Detective details: When 2 Way valve temperature thermistor open or short-circuit is detected at power ON or while running the compressor.</p>
---	--

Forecast of Cause:
 1. Connector connection failure 2. Thermistor failure 3. Main PCB failure

Test 1 : Check connection of Connector

- Check if connector is removed.
- Check erroneous connection.
- Check if thermistor cable is open.

>>Upon correcting the removed connector or miss-wiring, reset the power.



Test 2 : Remove connector and check Thermistor resistance value

Thermistor Characteristics (Approx. value)

Temperature (°C)	-30	-20	-10	0	10	20	30	40	50
Temperature (°F)	-22	-4	14	32	50	68	86	104	122
Resistance Value (kΩ)	1013.11	531.56	292.91	168.60	100.91	62.55	40.01	26.34	17.79

Temperature (°C)	60	70	80
Temperature (°F)	140	158	176
Resistance Value (kΩ)	12.30	8.70	6.27

► **If Thermistor is either open or shorted, replace it and reset the power.**



Test 3 : Check voltage of Main PCB (DC5.0V)

Make sure circuit diagram of outdoor unit and check terminal voltage at Thermistor (DC5.0V)

For AOU36RLXFZH

CN64	1	1	BLACK	VALVE THERMISTOR A, B
	2	2	BLACK	2-WAY VALVE A
	3	3	BLACK	3-WAY VALVE A
	4	4	BLACK	2-WAY VALVE B
	5	5	BLACK	3-WAY VALVE B
	6	6	BLACK	2-WAY VALVE C
	7	7	BLACK	3-WAY VALVE C
	8	8	BLACK	2-WAY VALVE D
CN65	1	1	BLACK	VALVE THERMISTOR C, D
	2	2	BLACK	2-WAY VALVE C
	3	3	BLACK	3-WAY VALVE C
	4	4	BLACK	2-WAY VALVE D
	5	5	BLACK	3-WAY VALVE D
	6	6	BLACK	2-WAY VALVE E
	7	7	BLACK	3-WAY VALVE E
	8	8	BLACK	2-WAY VALVE F
	9	9	BLACK	3-WAY VALVE F

For AOU45RLXFZ

CN64	1	1	BLACK	VALVE THERMISTOR A, B
	2	2	BLACK	2-WAY VALVE A
	3	3	BLACK	3-WAY VALVE A
	4	4	BLACK	2-WAY VALVE B
	5	5	BLACK	3-WAY VALVE B
	6	6	BLACK	2-WAY VALVE C
	7	7	BLACK	3-WAY VALVE C
	8	8	BLACK	2-WAY VALVE D
CN65	1	1	BLACK	VALVE THERMISTOR C, D
	2	2	BLACK	2-WAY VALVE C
	3	3	BLACK	3-WAY VALVE C
	4	4	BLACK	2-WAY VALVE D
	5	5	BLACK	3-WAY VALVE D
	6	6	BLACK	2-WAY VALVE E
	7	7	BLACK	3-WAY VALVE E
	8	8	BLACK	2-WAY VALVE F
	9	9	BLACK	3-WAY VALVE F

► **If the voltage does not appear, replace Main PCB.**

<p>Trouble shooting 27 OUTDOOR UNIT Error Method: 3-Way Valve Thermistor Error</p>	<p>Indicate or Display: Indoor Unit Operation lamp : 7 time Flash Timer lamp : 6 time Flash ERROR CODE : [E : 76]</p>	<p>Outdoor Unit</p> <table border="1" style="width: 100%; border-collapse: collapse; text-align: center;"> <tr> <th colspan="6">Monitor</th> </tr> <tr> <th>A</th> <th>B</th> <th>C</th> <th>D</th> <th>E</th> <th>F</th> </tr> <tr> <td>● 7</td> <td>● 6</td> <td>○</td> <td>○</td> <td>●</td> <td>○</td> </tr> </table> <p>● : Light ON ○ : Light OFF ●n : n time blinking</p>	Monitor						A	B	C	D	E	F	● 7	● 6	○	○	●	○
Monitor																				
A	B	C	D	E	F															
● 7	● 6	○	○	●	○															

<p>Detective Actuators: Outdoor unit main PCB circuit 3 Way valve temperature thermistor</p>	<p>Detective details: When 3 Way valve temperature thermistor open or short-circuit is detected at power ON or while running the compressor.</p>
---	--

Forecast of Cause:
 1. Connector connection failure 2. Thermistor failure 3. Main PCB failure

Test 1 : Check connection of Connector

- Check if connector is removed.
- Check erroneous connection.
- Check if thermistor cable is open.

>>Upon correcting the removed connector or miss-wiring, reset the power.



Test 2 : Remove connector and check Thermistor resistance value

Thermistor Characteristics (Approx. value)

Temperature (°C)	-30	-20	-10	0	10	20	30	40	50
Temperature (°F)	-22	-4	14	32	50	68	86	104	122
Resistance Value (kΩ)	1013.11	531.56	292.91	168.60	100.91	62.55	40.01	26.34	17.79

Temperature (°C)	60	70	80
Temperature (°F)	140	158	176
Resistance Value (kΩ)	12.30	8.70	6.27

► **If Thermistor is either open or shorted, replace it and reset the power.**



Test 3 : Check voltage of Main PCB (DC5.0V)

Make sure circuit diagram of outdoor unit and check terminal voltage at Thermistor (DC5.0V)

For AOU36RLXFZH

CN64	1	1	BLACK	VALVE THERMISTOR A, B
	2	2	BLACK	2-WAY VALVE A
	3	3	BLACK	3-WAY VALVE A
	4	4	BLACK	3-WAY VALVE A
	5	5	BLACK	2-WAY VALVE B
	6	6	BLACK	2-WAY VALVE B
	7	7	BLACK	3-WAY VALVE B
	8	8	BLACK	3-WAY VALVE B
CN65	1	1	BLACK	VALVE THERMISTOR C, D
	2	2	BLACK	2-WAY VALVE C
	3	3	BLACK	2-WAY VALVE C
	4	4	BLACK	3-WAY VALVE C
	5	5	BLACK	3-WAY VALVE C
	6	6	BLACK	2-WAY VALVE D
	7	7	BLACK	2-WAY VALVE D
	8	8	BLACK	3-WAY VALVE D
	9	9	BLACK	3-WAY VALVE D

For AOU45RLXFZ

CN64	1	1	BLACK	VALVE THERMISTOR A, B
	2	2	BLACK	2-WAY VALVE A
	3	3	BLACK	3-WAY VALVE A
	4	4	BLACK	3-WAY VALVE A
	5	5	BLACK	2-WAY VALVE B
	6	6	BLACK	2-WAY VALVE B
	7	7	BLACK	3-WAY VALVE B
	8	8	BLACK	3-WAY VALVE B
CN65	1	1	BLACK	VALVE THERMISTOR C, D
	2	2	BLACK	2-WAY VALVE C
	3	3	BLACK	2-WAY VALVE C
	4	4	BLACK	3-WAY VALVE C
	5	5	BLACK	3-WAY VALVE C
	6	6	BLACK	2-WAY VALVE D
	7	7	BLACK	2-WAY VALVE D
	8	8	BLACK	3-WAY VALVE D
	9	9	BLACK	3-WAY VALVE D
CN66	1	1	BLACK	VALVE THERMISTOR E
	2	2	BLACK	2-WAY VALVE E
	3	3	BLACK	2-WAY VALVE E
	4	4	BLACK	3-WAY VALVE E
	5	5	BLACK	3-WAY VALVE E
	6	6		
	7	7		
	8	8		
	9	9		

► **If the voltage does not appear, replace Main PCB.**

Trouble shooting 28 OUTDOOR UNIT Error Method: CT Error	Indicate or Display: Indoor Unit Operation lamp : 8 time Flash Timer lamp : 4 time Flash ERROR CODE : [E : 84]	Outdoor Unit <table border="1"> <thead> <tr> <th colspan="6">Monitor</th> </tr> <tr> <th>A</th> <th>B</th> <th>C</th> <th>D</th> <th>E</th> <th>F</th> </tr> </thead> <tbody> <tr> <td>● 8</td> <td>● 4</td> <td>○</td> <td>○</td> <td>○</td> <td>●</td> </tr> </tbody> </table> ● : Light ON ○ : Light OFF ● n : n time blinking	Monitor						A	B	C	D	E	F	● 8	● 4	○	○	○	●
	Monitor																			
A	B	C	D	E	F															
● 8	● 4	○	○	○	●															

Detective Actuators: Outdoor unit main PCB	Detective details: When Input Current Sensor has detected 0A, while Inverter Compressor is operating at higher than 60 rps, after 1 minutes upon starting the Compressor. (Except during the defrost operation)
--	---

Forecast of Cause: 1. Defective connection of electric components 2. External cause 3. Main PCB failure

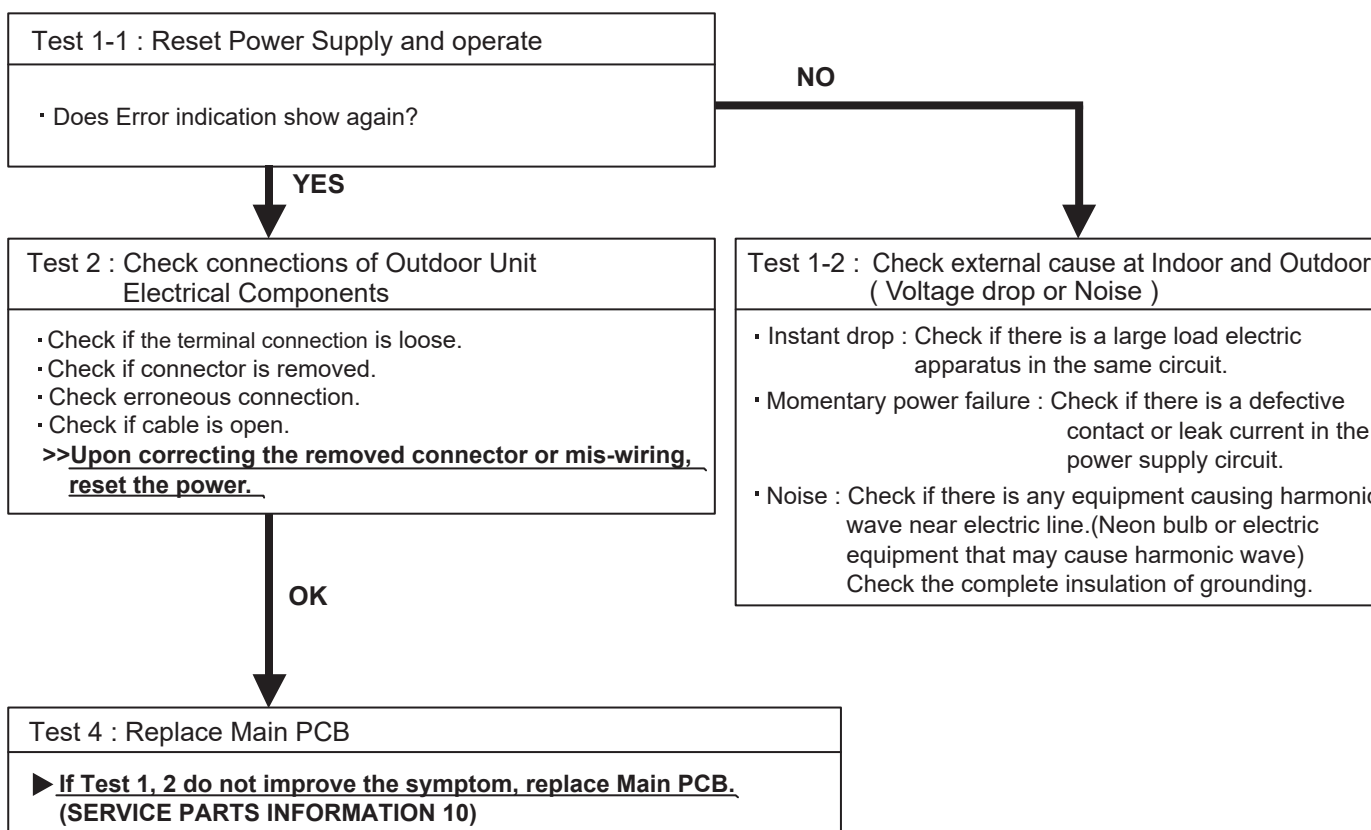

<p>Trouble shooting 29 OUTDOOR UNIT Error Method: Discharge Pressure Sensor Error</p>	<p>Indicate or Display: Indoor Unit Operation lamp : 8 time Flash Timer lamp : 6 time Flash ERROR CODE : [E : 86]</p>	<p>Outdoor Unit</p> <table border="1" style="margin-left: auto; margin-right: auto; border-collapse: collapse; text-align: center;"> <tr> <th colspan="6">Monitor</th> </tr> <tr> <th>A</th> <th>B</th> <th>C</th> <th>D</th> <th>E</th> <th>F</th> </tr> <tr> <td>● 8</td> <td>● 6</td> <td>○</td> <td>○</td> <td>○</td> <td>●</td> </tr> </table> <p style="font-size: small; text-align: center;">● : Light ON ○ : Light OFF ●n : n time blinking</p>	Monitor						A	B	C	D	E	F	● 8	● 6	○	○	○	●
Monitor																				
A	B	C	D	E	F															
● 8	● 6	○	○	○	●															

<p>Detective Actuators: Discharge pressure sensor</p>	<p>Detective details:</p> <ul style="list-style-type: none"> • When any of the following conditions is satisfied, a discharge pressure sensor error is generated. <ul style="list-style-type: none"> ① 30 seconds or more have elapsed since the outdoor unit power was turned on and pressure sensor detected value < 0.3V continued for 30 seconds or more ② 30 seconds or more have elapsed since the outdoor unit power was turned on and pressure sensor detected value ≥ 5.0V was detected.
---	---

Forecast of Cause:

1. Discharge pressure sensor connector disconnection, open
2. Discharge pressure sensor failure
3. Main PCB failure

Test 1 : Check the discharge pressure sensor connection state

- Connector connection state check
- Cable open check



Test 2 : Check the discharge pressure sensor

- Sensor characteristics check
 *For the characteristics of the discharge pressure sensor, refer to the **(SERVICE PARTS INFORMATION 4)**.



<p>Test 3 : Check voltage of Main PCB (DC5.0V)</p> <ul style="list-style-type: none"> <input type="checkbox"/> Main PCB (CN92:1-3) voltage value = 5V Remove the PRESSURE SENSOR from Main PCB, check the voltage. 	<div style="border: 1px solid black; padding: 2px; width: 30px; margin: 0 auto;">DC</div>
<p>Discharge pressure sensor (CN92:1-3)</p> <p>▶ <u>If the voltage does not appear, replace Main PCB, and execute the check operation again.</u></p>	

<p>Trouble shooting 30 OUTDOOR UNIT Error Method: Over Current Error</p>	<p>Indicate or Display: Indoor Unit Operation lamp : 9 time Flash Timer lamp : 4 time Flash ERROR CODE : [E : 94]</p>	<p>Outdoor Unit</p> <table border="1" data-bbox="1161 347 1570 428"> <thead> <tr> <th colspan="6">Monitor</th> </tr> <tr> <th>A</th> <th>B</th> <th>C</th> <th>D</th> <th>E</th> <th>F</th> </tr> </thead> <tbody> <tr> <td>● 9</td> <td>● 4</td> <td>○</td> <td>○</td> <td>○</td> <td>●</td> </tr> </tbody> </table> <p>● : Light ON ○ : Light OFF ● n : n time blinking</p>	Monitor						A	B	C	D	E	F	● 9	● 4	○	○	○	●
Monitor																				
A	B	C	D	E	F															
● 9	● 4	○	○	○	●															

<p>Detective Actuators: Outdoor unit main PCB circuit Outdoor fan motor Compressor</p>	<p>Detective details: “Protection stop by overcurrent generation after inverter compressor start processing completed” generated consecutively 5 times. * The number of generations is reset if the start-up of the compressor succeeds.</p>
--	---

<p>Forecast of Cause: 1. Outdoor Heat Exchanger clogged 2. Outdoor Fan Operation failure 3. Main PCB 4. Inverter compressor failure (lock, winding short)</p>
--

<p>Test 1 : Check ambient temp. around motor,Heat Exchanger</p> <ul style="list-style-type: none"> • Check excessively high temperature around the motor. (If there is any surrounding equipment that causes heat) • Is there anything obstructing the air distribution circuit? • Is there any clogging of Outdoor Heat Exchanger? <p>>> <u>Upon the temperature coming down, restart operation.</u></p>

↓
OK

<p>Test 2 : Check Outdoor Fan</p> <ul style="list-style-type: none"> • Is the Fan rotating by hand when operation is off? <p>>> <u>If the Fan Motor is locked, replace it.</u></p>
--

↓
OK

<p>Test 3 : Replace Main PCB</p> <p>▶ <u>If Test 1 - 2 do not improve the symptom, change Main PCB.</u></p>
--

↓
OK

<p>Test 4 : Replace Compressor</p> <p>▶ <u>If Test 3 do not improve the symptom, change Compressor.</u></p>
--

Trouble shooting 31 OUTDOOR UNIT Error Method: Compressor Control Error	Indicate or Display: Indoor Unit Operation lamp : 9 time Flash Timer lamp : 5 time Flash ERROR CODE : [E : 95]	Outdoor Unit <table border="1" data-bbox="1161 347 1572 428"> <thead> <tr> <th colspan="6">Monitor</th> </tr> <tr> <th>A</th> <th>B</th> <th>C</th> <th>D</th> <th>E</th> <th>F</th> </tr> </thead> <tbody> <tr> <td>● 9</td> <td>● 5</td> <td>○</td> <td>○</td> <td>○</td> <td>●</td> </tr> </tbody> </table> <p>● : Light ON ○ : Light OFF ● n : n time blinking</p>	Monitor						A	B	C	D	E	F	● 9	● 5	○	○	○	●
Monitor																				
A	B	C	D	E	F															
● 9	● 5	○	○	○	●															

Detective Actuators: Outdoor unit main PCB Compressor	Detective details: <ol style="list-style-type: none"> ① While running the compressor, if the detected rotor location is out of phase with actual rotor location more than 105°, the compressor stops. ② After the compressor restarts, if the same operation is repeated within 40 sec, the compressor stops again. ③ If ① and ② repeats 5 times, the compressor stops permanently.
--	---

Forecast of Cause: 1. Defective connection of electric components 2. Main PCB failure 3. Compressor failure

Test 1 : Check connection of around the Compressor components
For Compressor Terminal, Main PCB <ul style="list-style-type: none"> • Check if connector is removed. • Check erroneous connection. • Check if cable is open. (SERVICE PARTS INFORMATION 2) >>Upon correcting the removed connector or miss-wiring, reset the power.

↓
OK

Test 2 : Replace Main PCB
▶ If Test 1 do not improve the symptom, change Main PCB. (SERVICE PARTS INFORMATION 10)

↓
OK

Test 3 : Replace Compressor
▶ If Test 2 do not improve the symptom, change Compressor.

Trouble shooting 32 OUTDOOR UNIT Error Method: Outdoor Unit Fan Motor Error	Indicate or Display: Indoor Unit Operation lamp : 9 time Flash Timer lamp : 7 time Flash ERROR CODE : [E : 97]	Outdoor Unit <table border="1"> <tr> <th colspan="6">Monitor</th> </tr> <tr> <th>A</th> <th>B</th> <th>C</th> <th>D</th> <th>E</th> <th>F</th> </tr> <tr> <td>● 9</td> <td>● 7</td> <td>○</td> <td>○</td> <td>●</td> <td>●</td> </tr> </table> <p>● : Light ON ○ : Light OFF ●n : n time blinking</p>	Monitor						A	B	C	D	E	F	● 9	● 7	○	○	●	●
	Monitor																			
A	B	C	D	E	F															
● 9	● 7	○	○	●	●															

Detective Actuators: Outdoor unit main PCB circuit Outdoor unit fan motor	Detective details: ① When outdoor unit fan rotation speed is less than 100 rpm in 20 seconds after fan motor starts, fan motor stops. ② After fan motor restarts, if the same operation within 60 sec is repeated 3 times in a row, compressor and fan motor stops. ③ If ① and ② repeats 5 times in a row, compressor and fan motor stops permanently.
--	--

Forecast of Cause:

1. Fan rotation failure 2. Motor protection by surrounding temperature rise 3. Main PCB failure
 4. Outdoor unit fan motor failure

Test 1 : Check rotation of Fan

- Rotate the fan by hand when operation is off.
 (Check if fan is caught, dropped off or locked motor)

>>If Fan or Bearing is abnormal, replace it.

↓ OK

Test 2 : Check ambient temp. around motor

- Check excessively high temperature around the motor.
 (If there is any surrounding equipment that causes heat)

>>Upon the temperature coming down, restart operation.

↓ OK

Test 3 : Check Outdoor unit fan motor

- Check Outdoor unit fan motor. **(PARTS INFORMATION 6)**

>>If Outdoor Fan Motor is abnormal, replace Outdoor fan motor and Main PCB.

↓ OK

Test 4 : Check Output Voltage of Main PCB

- Check outdoor unit circuit diagram and the voltage. (Measure at Main PCB side connector)

Read wire	DC voltage
Red - Black	260 - 400V
White - Black	15 ± 1.5V

▶ **If the voltage is not correct, replace Main PCB.**
(SERVICE PARTS INFORMATION 10)

Trouble shooting 33 OUTDOOR UNIT Error Method: 4-Way Valve Error	Indicate or Display: Indoor Unit Operation lamp : 9 time Flash Timer lamp : 9 time Flash ERROR CODE : [E : 99]	Outdoor Unit <table border="1"> <thead> <tr> <th colspan="6">Monitor</th> </tr> <tr> <th>A</th> <th>B</th> <th>C</th> <th>D</th> <th>E</th> <th>F</th> </tr> </thead> <tbody> <tr> <td>● 9</td> <td>● 9</td> <td>○</td> <td>○</td> <td>○</td> <td>●</td> </tr> </tbody> </table> <p>● : Light ON ○ : Light OFF ● n : n time blinking</p>	Monitor						A	B	C	D	E	F	● 9	● 9	○	○	○	●
	Monitor																			
A	B	C	D	E	F															
● 9	● 9	○	○	○	●															

Detective Actuators: Indoor unit main PCB Heat Ex. temperature thermistor Room temperature thermistor 4-Way valve	Detective details: When the indoor unit Heat Ex. temperature is compared with the room temperature, and either following condition is detected continuously 2 times, compressor stops. <ul style="list-style-type: none"> • Cooling operation [Indoor Heat Ex. temperature] - [Room temperature] > 20°F(10°C) • Heating operation [Indoor Heat Ex. temperature] - [Room temperature] < -20°F(-10°C) If the same operation is repeated 5 times, the compressor stops permanently.
--	--

Forecast of Cause: 1. Connector connection failure 2. Thermistor failure 3. Coil failure 4. 4-way valve failure 5. Main PCB failure 6. Controller PCB failure
--

Test 1 : Check connection of Connector <ul style="list-style-type: none"> • Check if connector is removed. • Check erroneous connection. • Check if thermistor cable is open. >> Upon correcting the removed connector or miss-wiring, reset the power.



Test 2 : Check thermistor of Indoor unit <ul style="list-style-type: none"> • Isn't it fallen off the holder? • Is there a cable pinched? >> Check characteristics of thermistor, (Refer to Trouble shooting 8,9), If defective, replace the thermistor.



Test 3 : Check the solenoid coil and 4-way valve [Solenoid coil] <ul style="list-style-type: none"> • Remove CN202 from PCB and check the resistance value of coil. Resistance value is about 2085Ω±10% (68°F(20°C)) >> If it is Open or abnormal resistance value, replace Solenoid Coil. [4-way valve] <ul style="list-style-type: none"> • Check each piping temperature, and the location of the valve by the temperature difference. >> If the value location is not proper, replace 4-way valve.
--



Test 4 : Check the voltage of 4-way valve <ul style="list-style-type: none"> • Check the CN202 voltage of Main PCB Check if AC187V(AC208V-10%) - 253V(AC230V+10%) appears at CN 202 of Main PCB. [Heating operation] >> If it is not voltage, Replace Main PCB. (SERVICE PARTS INFORMATION 10) [Cooling operation] >> If it is voltage, Replace Main PCB. (SERVICE PARTS INFORMATION 10)	
--	--



Test 5 : Replace Controller PCB ► If Test 1- 4 do not improve the symptom, replace Controller PCB of Indoor unit .

Trouble shooting 34 OUTDOOR UNIT Error Method: Coil (expansion valve) Error	Indicate of Display: Indoor Unit Operation lamp : 9 time Flash Timer lamp : 10 time Flash ERROR CODE : [E : 9A]	Outdoor Unit <table border="1"> <thead> <tr> <th colspan="6">Monitor</th> </tr> <tr> <th>A</th> <th>B</th> <th>C</th> <th>D</th> <th>E</th> <th>F</th> </tr> </thead> <tbody> <tr> <td>● 9</td> <td>● 10</td> <td>○</td> <td>○</td> <td>○</td> <td>●</td> </tr> </tbody> </table> <p>● : Light ON ○ : Light OFF ●n : n time blinking</p>	Monitor						A	B	C	D	E	F	● 9	● 10	○	○	○	●
	Monitor																			
A	B	C	D	E	F															
● 9	● 10	○	○	○	●															
Detective Actuators: EEV Coil Main PCB																				

Detective details: Coil (Expansion valve) driver circuit open detected.

Forecast of Cause: 1. EEV coil loose connection 2. EEV wires cut or pinched. 3. Defective EEV coil 4. Main PCB (DC12V) output abnormal

Test 1 : Check the connection of EEV connector • Check if the connector is loose connection or not.

↓ OK

Test 2 : Check the EEV wire • Check if the wire of EEV has damage or not. (Slash, Braking of wire, Pinching, etc.)	NG → Replace EEV Coil
---	-----------------------

↓ OK

Test 3 : Check the EEV Coil • Check if the circuit of EEV coil winding is good or not. (Refer to the service parts information 3)	NG → Replace EEV Coil
--	-----------------------

↓ OK

Test 4 : Check the output of EEV on the Main PCB • Check if the DC12V is on between the Pin No.1 of CN111-115 and GND Pin. (Disconnect the wire of EEV when you check the output of EEV)

↓ OK

↓ NG

• Replace Main PCB (SERVICE PARTS INFORMATION 10)

Test 5 : Noise, momentary open, voltage drop • Check if temporary voltage drop was not generated. • Check if momentary open was not generated. • Check if ground is connection correctly or there are no related cables near the power line.
--

Trouble shooting 35 OUTDOOR UNIT Error Method: Discharge Temperature Error	Indicate of Display: Indoor Unit Operation lamp : 10 time Flash Timer lamp : 1 time Flash ERROR CODE : [E : A1]	Outdoor Unit <table border="1" style="margin-left: auto; margin-right: auto;"> <thead> <tr> <th colspan="6">Monitor</th> </tr> <tr> <th>A</th> <th>B</th> <th>C</th> <th>D</th> <th>E</th> <th>F</th> </tr> </thead> <tbody> <tr> <td style="text-align: center;">● 10</td> <td style="text-align: center;">● 1</td> <td style="text-align: center;">○</td> <td style="text-align: center;">○</td> <td style="text-align: center;">○</td> <td style="text-align: center;">●</td> </tr> </tbody> </table> <p style="text-align: center; font-size: small;">● : Light ON ○ : Light OFF ●n : n time blinking</p>	Monitor						A	B	C	D	E	F	● 10	● 1	○	○	○	●
Monitor																				
A	B	C	D	E	F															
● 10	● 1	○	○	○	●															
Detective Actuators: Outdoor unit main PCB Discharge pipe temperature thermistor	Detective details: Protection stop by Discharge pipe temperature thermistor $\geq 230^{\circ}\text{F}(110^{\circ}\text{C})$ during compressor operation generated 2 times within 24 hours.																			
Forecast of Cause: 1. 3-way valve not opened 2. EEV defective, strainer clogged 3. Outdoor unit operation failure, foreign matter on heat exchanger 4. Discharge temperature thermistor failure 5. Insufficient refrigerant 6. Main PCB failure																				

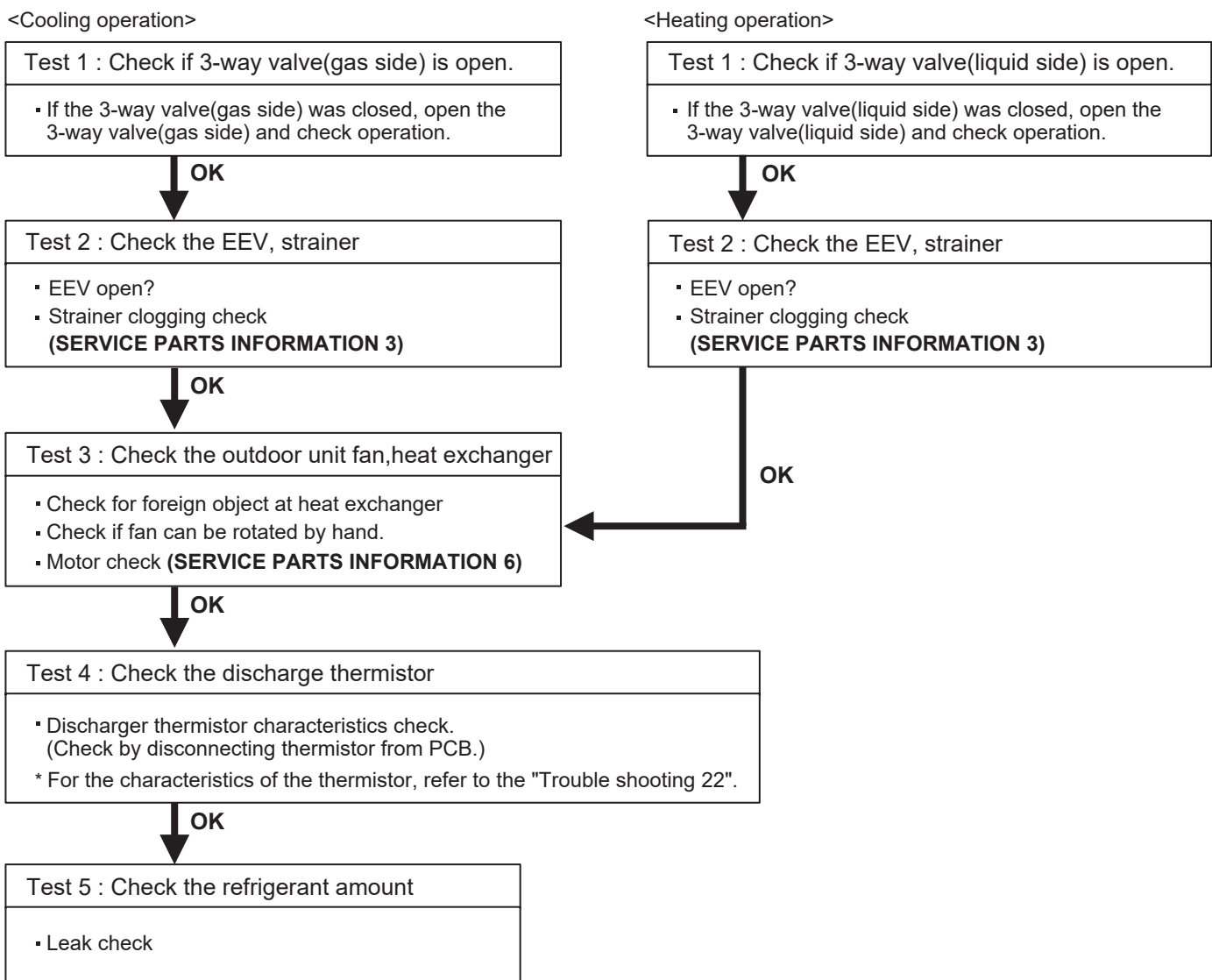

Trouble shooting 36 OUTDOOR UNIT Error Method: Compressor Temperature Error	Indicate of Display: Indoor Unit Operation lamp : 10 time Flash Timer lamp : 3 time Flash ERROR CODE : [E : A3]	Outdoor Unit <table border="1"> <thead> <tr> <th colspan="6">Monitor</th> </tr> <tr> <th>A</th> <th>B</th> <th>C</th> <th>D</th> <th>E</th> <th>F</th> </tr> </thead> <tbody> <tr> <td>● 10</td> <td>● 3</td> <td>○</td> <td>○</td> <td>○</td> <td>●</td> </tr> </tbody> </table> ● : Light ON ○ : Light OFF ●n : n time blinking	Monitor						A	B	C	D	E	F	● 10	● 3	○	○	○	●
	Monitor																			
A	B	C	D	E	F															
● 10	● 3	○	○	○	●															

Detective Actuators: Compressor temperature thermistor	Detective details: Protection stop by Compressor temperature thermistor $\geq 226.4^{\circ}\text{F}(108^{\circ}\text{C})$ during compressor operation generated 2 times within 24 hours.
--	--

Forecast of Cause: 1. 3-way valve not opened 2. EEV defective, strainer clogged 3. Outdoor unit operation failure, foreign matter on heat exchanger 4. Compressor temperature thermistor failure 5. Insufficient refrigerant 6. Main PCB failure

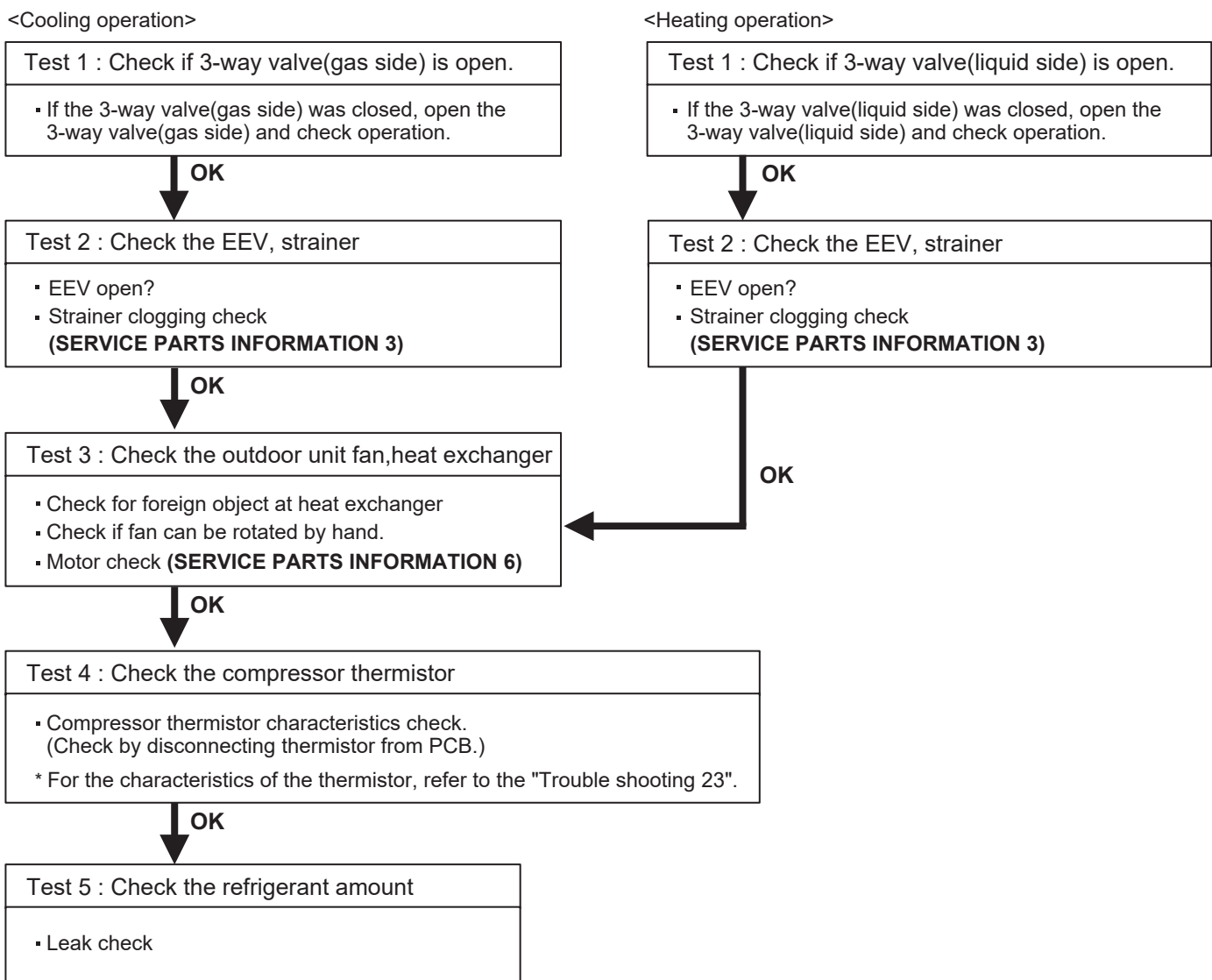

2-3 TROUBLE SHOOTING WITH NO ERROR CODE

Trouble shooting 37

Indoor unit - No Power

Forecast of Cause :

1. Power supply failure.
2. External cause.
3. Electrical components defective.

Test 1 : Check Installation Condition

- Isn't the breaker down?
- Check loose or removed connection cable.
- >> **If abnormal condition is found, correct it by referring to Installation Manual or Data & Technical Manual.**

OK

Test 2 : Check external cause at Indoor and Outdoor (Voltage drop or Noise)

- Instant drop ----- Check if there is a large load electric apparatus in the same circuit.
- Momentary power failure ----- Check if there is a defective contact or leak current in the power supply circuit.
- Noise ----- Check if there is any equipment causing harmonic wave near electric line.
(Neon bulb or electric equipment that may cause harmonic wave)
Check the complete insulation of grounding.

OK

Test 3 : Check Electrical Components

- Check the voltage of power supply.
- >> **Check if AC187 - 253V appears at Outdoor Unit Terminal L1 - L2.**



YES

- Check Fuse of between of Terminal and Filter PCB.
- >> **If Fuse is open, check if the wiring between Terminal and Filter PCB is loose, and replace Fuse.**
- Check Varistor in Filter PCB.
- >> **If Varistor is defective, there is a possibility of an abnormal power supply. Check the correct power supply and replace Varistor. Upon checking the normal power supply, replace Varistor.**

OK

Test 4 : Replace Filter PCB

- ▶ **If Test 1- 3 do not improve the symptom, replace Filter PCB.**

Trouble shooting 38

Outdoor unit - No Power

Forecast of Cause :

1. Power supply failure.
2. External cause.
3. Electrical components defective.

Test 1 : Check Installation Condition

- Isn't the breaker down?
- Check loose or removed connection cable.
- >> **If abnormal condition is found, correct it by referring to Installation Manual or Data & Technical Manual.**

OK

Test 2 : Check external cause at Indoor and Outdoor (Voltage drop or Noise)

- Instant drop ----- Check if there is a large load electric apparatus in the same circuit.
- Momentary power failure ----- Check if there is a defective contact or leak current in the power supply circuit.
- Noise ----- Check if there is any equipment causing harmonic wave near electric line.
(Neon bulb or electric equipment that may cause harmonic wave)
Check the complete insulation of grounding.

OK

Test 3 : Check Electrical Components



- Check the voltage of power supply.
- >> **Check if AC187 - 253V appears at Outdoor Unit Terminal L1 - L2.**

YES

- Check Fuse in Main PCB.
- >> **If Fuse is open, check if the wiring between Terminal and Main PCB is loose, and replace Fuse.**

YES

- Check Active Filter Module. (PARTS INFORMATION 8)
- >> **If Active Filter Module is abnormal, replace it.**

OK

Test 4 : Replace Main PCB

- ▶ **If Test 1- 3 do not improve the symptom, replace Main PCB.**
(SERVICE PARTS INFORMATION 10)

Trouble shooting 39

No Operation (Power is ON)

Forecast of Cause :

1. Setting / Connection failure.
2. External cause.
3. Electrical components defective.

Test 1 : Check indoor and outdoor installation condition

- Indoor Unit - Check incorrect wiring between Indoor Unit - Remote Control.
Or, check if there is an open cable connection.
- Are these Indoor unit, Outdoor unit, and Remote control suitable model numbers to connect?
>> If there is some abnormal condition, correct it by referring to Installation manual and Data & Technical Manual.

OK

Turn off Power and check/ correct followings.

- Is there loose or removed communication line of Indoor unit and Outdoor unit?

OK

Test 2 : Check external cause at Indoor and Outdoor (Voltage drop or Noise)

- Instant drop ----- Check if there is a large load electric apparatus in the same circuit.
- Momentary power failure ----- Check if there is a defective contact or leak current in the power supply circuit.
- Noise ----- Check if there is any equipment causing harmonic wave near electric line.
(Neon bulb or electric equipment that may cause harmonic wave)
Check the complete insulation of grounding.

OK

Test 3 : Check Wired Remote Controller and Controller PCB

- Check Voltage at terminal 1-3 of Controller PCB or Communication PCB.
(Power supply to Remote Control)
Compact Cassette, Slim Duct Type : CN14
Wall Mount , Floor Type : CN16
Compact Wall Mount Type : CNC01(UTY-XCBXZ2)

- >> If it is DC12V, Remote Control is failure. (Controller PCB is normal) >> Replace Remote Control**
- >> If it is DC 0V, Controller PCB is failure. (Check Remote Control once again)**
 - >> Check Indoor unit fan motor. (SERVICE PARTS INFORMATION 5)**
 - If it is normal, replace Controller PCB.
 - If it is abnormal, replace Indoor unit fan motor and Controller PCB.
- >> If the symptom does not change by above Check 1, 2, 3, replace Main PCB of Outdoor unit. (SERVICE PARTS INFORMATION 10)**

DC



Trouble shooting 40

No Cooling / No Heating

Forecast of Cause :

1. Indoor / Outdoor unit error.
2. Effect by surrounding environment.
3. Connection pipe / Connection wire failure
4. Refrigeration cycle failure.

Test 1 : Check Indoor Unit

- Does Indoor unit FAN run on HIGH FAN?
- Is Air filter dirty?
- Is Heat exchanger clogged?
- Check if Energy save function is operated.



Test 2 : Check Outdoor Unit Operation

- Check if Outdoor unit is operating
- Check any objects that obstruct the air flow route.
- Check clogged Heat exchanger.
- Is the Valve open?



Test 3 : Check Site Condition

- Is capacity of Indoor unit fitted to Room size?
- Any windows open? Or direct sunlight ?



Test 4 : Check Indoor/ Outdoor Installation Condition

- Check connection pipe (specified pipe length & Pipe diameter?)
- Check any loose or removed communication line.
- >> **If there is an abnormal condition, correct it by referring to Installation Manual or Data & Technical Manual.**



Test 5 : Check Refrigeration Cycle

- Check if Strainer is clogged (Refer to the figure at right).
- Measure Gas Pressure and if there is a leakage, correct it.
- >> **When recharging the refrigerant, make sure to perform vacuuming, and recharge the specified amount.**
- Check EEV (**SERVICE PARTS INFORMATION 3**)
- Check Compressor (**SERVICE PARTS INFORMATION 1,2**)
- Check Heater unit (**SERVICE PARTS INFORMATION 7**)

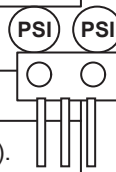

Attention

Strainer normally does not have temperature difference between inlet and outlet as shown in ①, but if there is a difference like shown in ②, there is a possibility of inside clogged. In this case, replace Strainer.

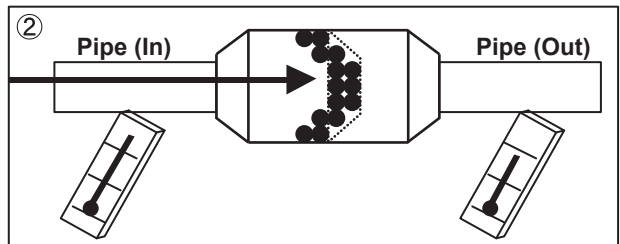
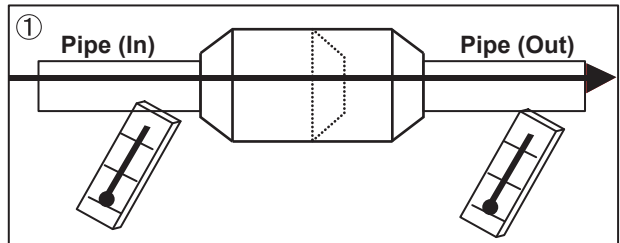

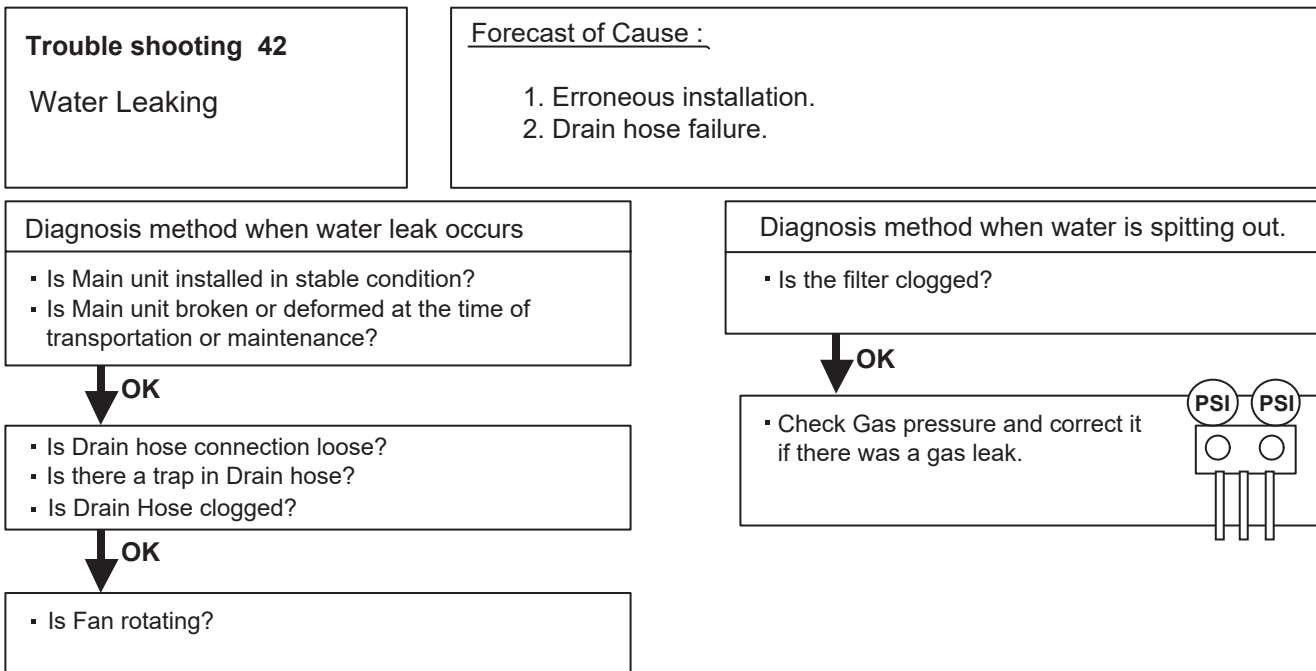
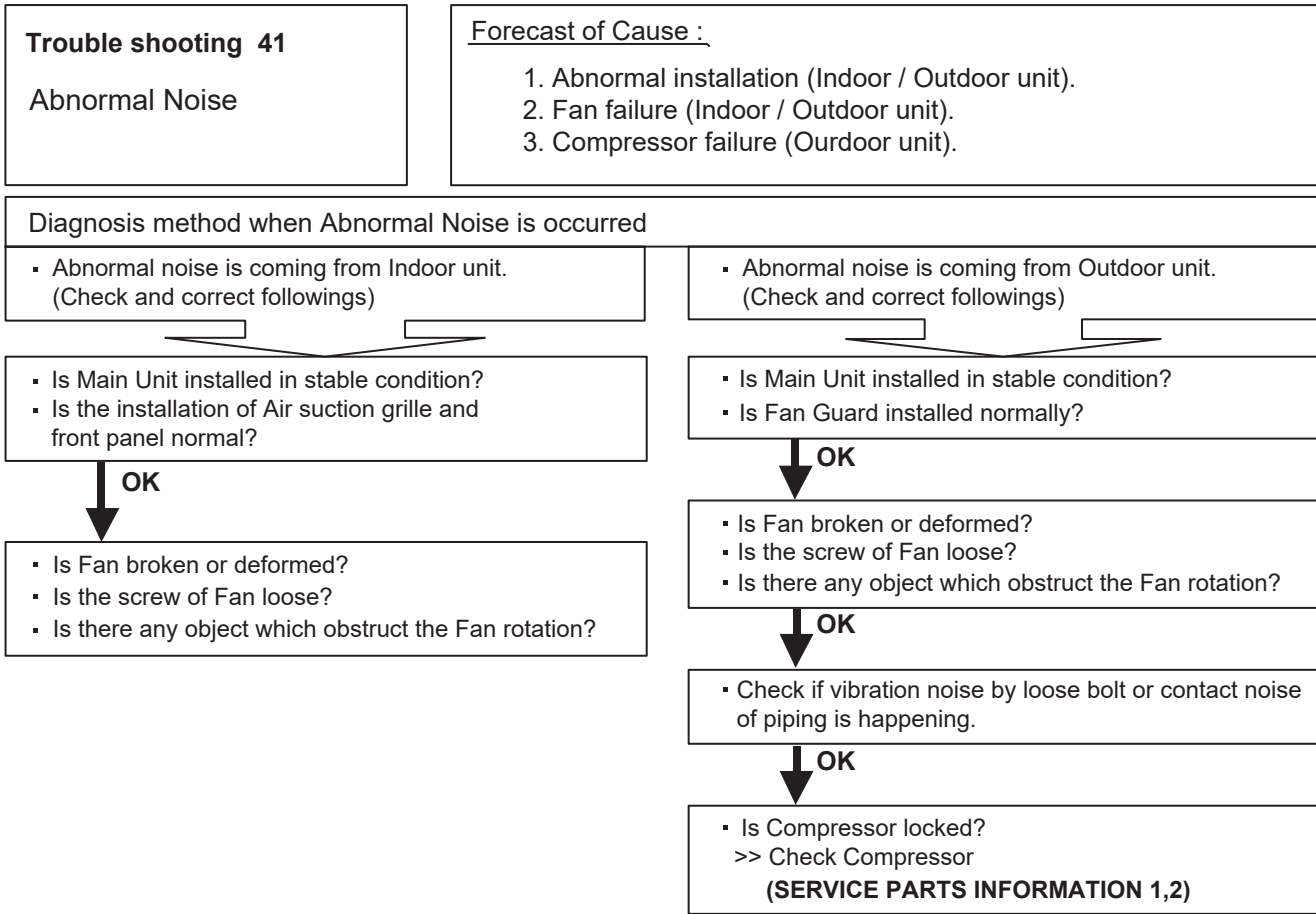

Trouble shooting 43
Too Warm

- Forecast of Cause :
1. House insulation setting has not been changed.
 2. Temperature sensing location has not been changed.
 3. Installation location of the wired remote.
 4. Function settings have not been changed.

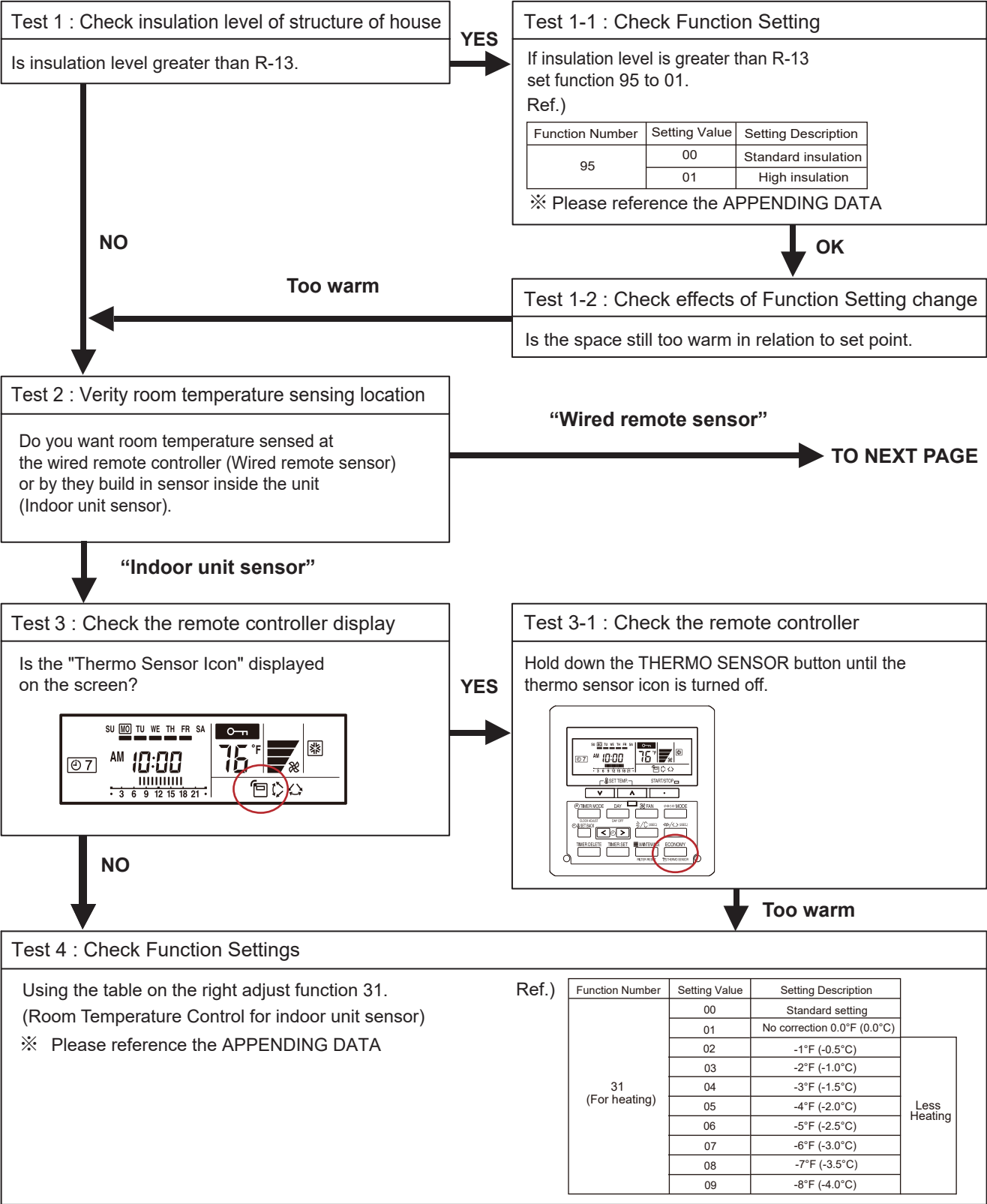

“Wired remote sensor”

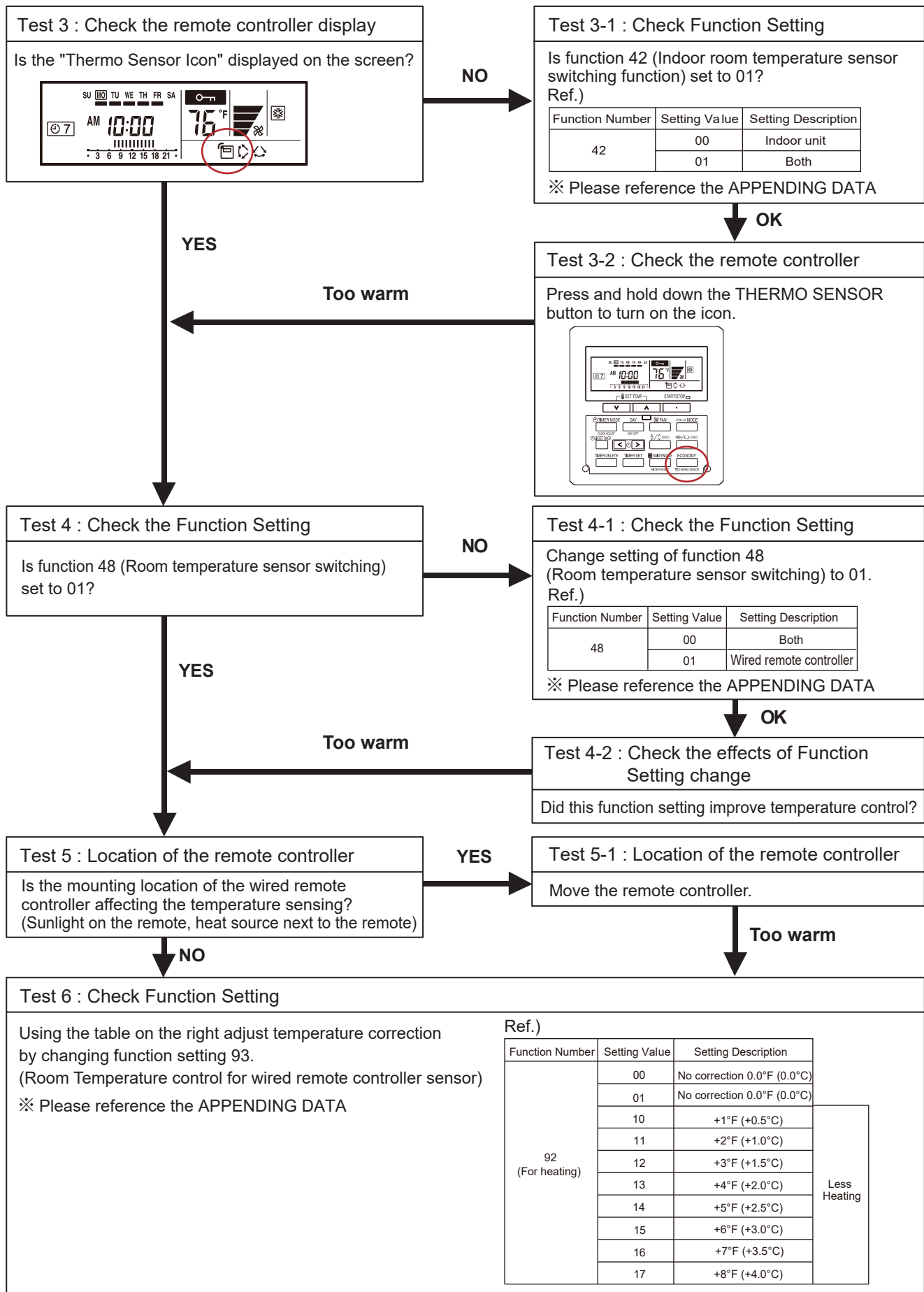

Trouble shooting 44
Too Cool

- Forecast of Cause :
1. House insulation setting has not been changed.
 2. Temperature sensing location has not been changed.
 3. Installation location of the wired remote.
 4. Function settings have not been changed.

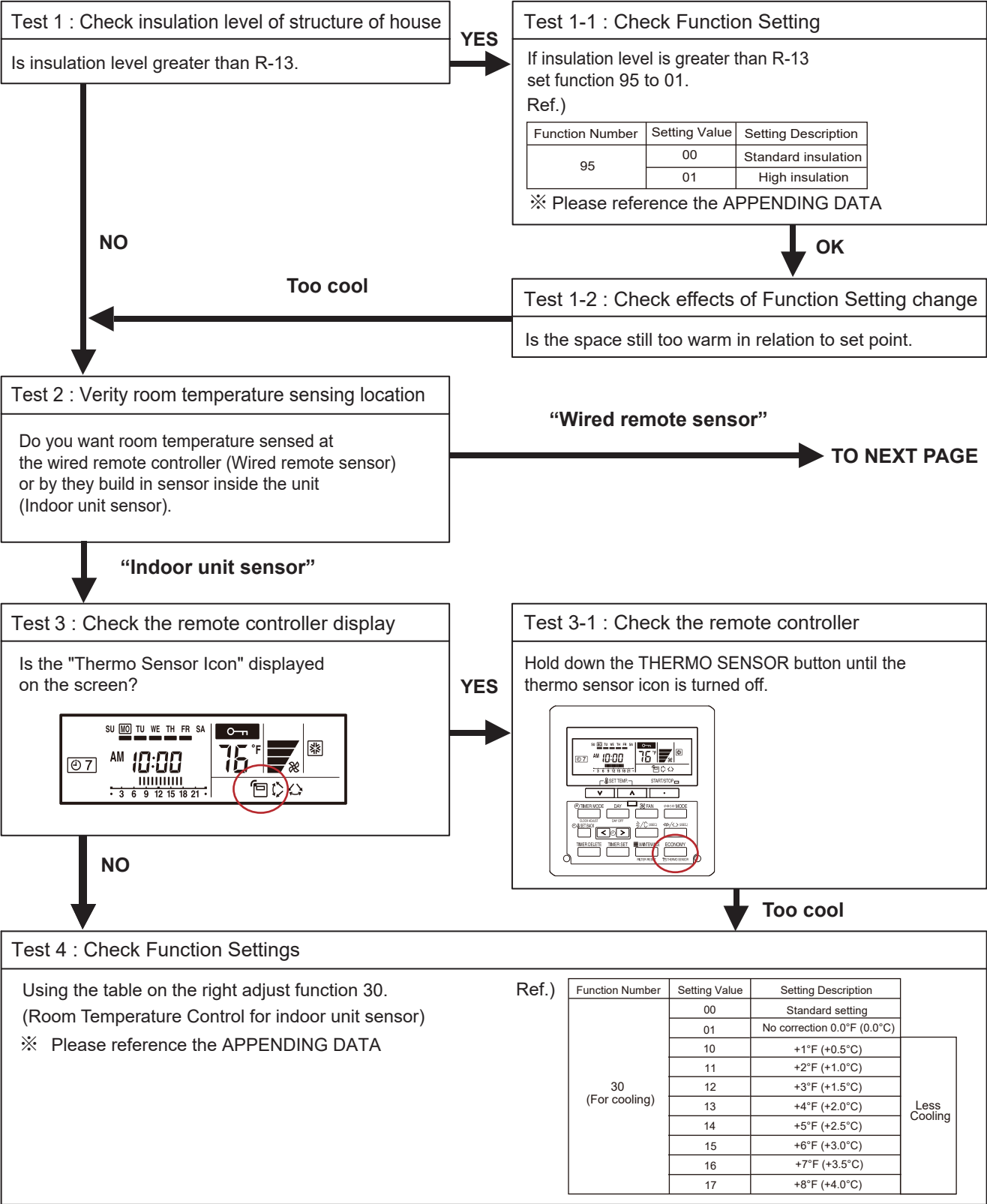

“Wired remote sensor”

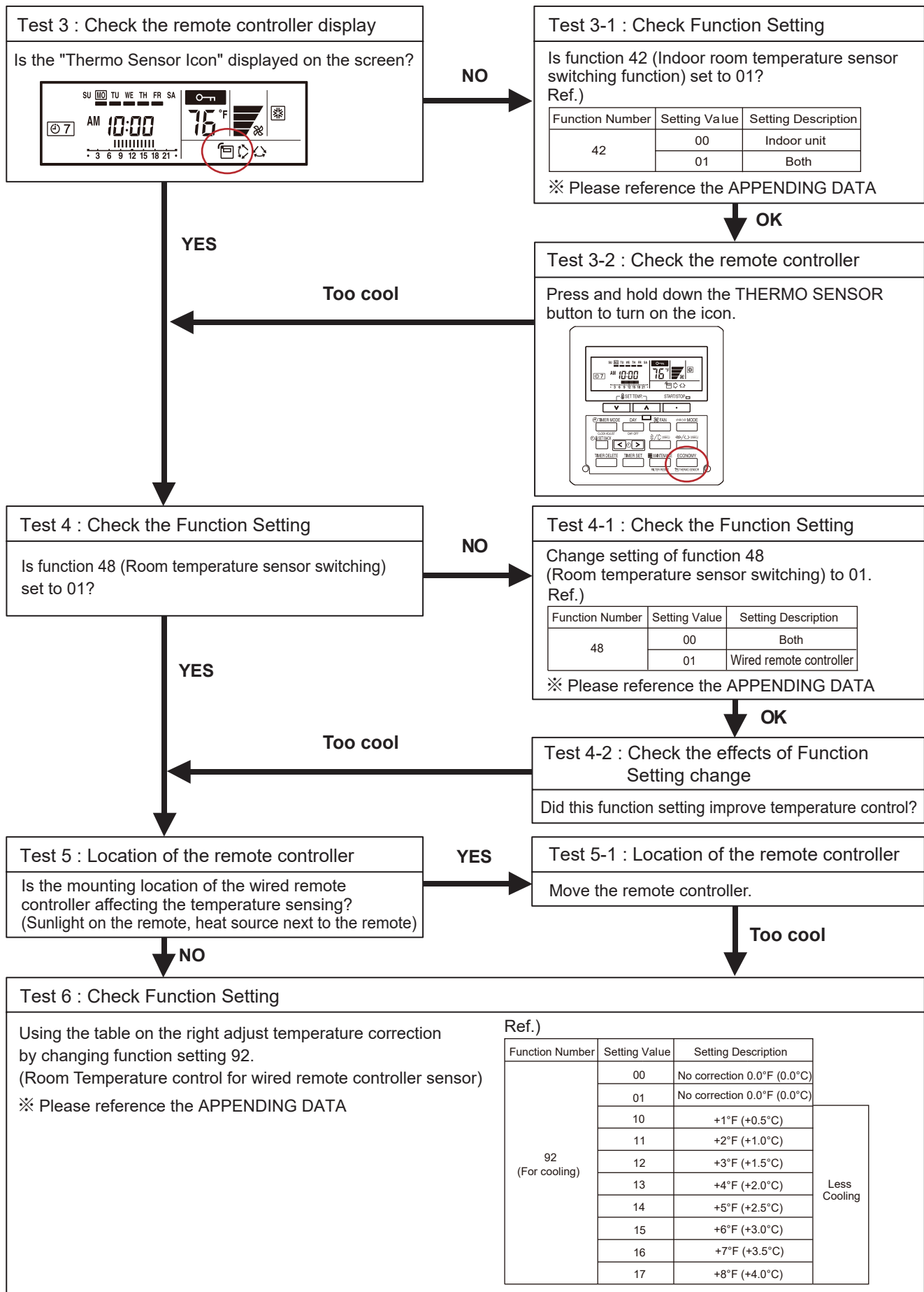

2-4 SERVICE PARTS INFORMATION

SERVICE PARTS INFORMATION 1

Compressor

Diagnosis method of Compressor (If Outdoor Unit LED displays Error, refer to Trouble shooting)

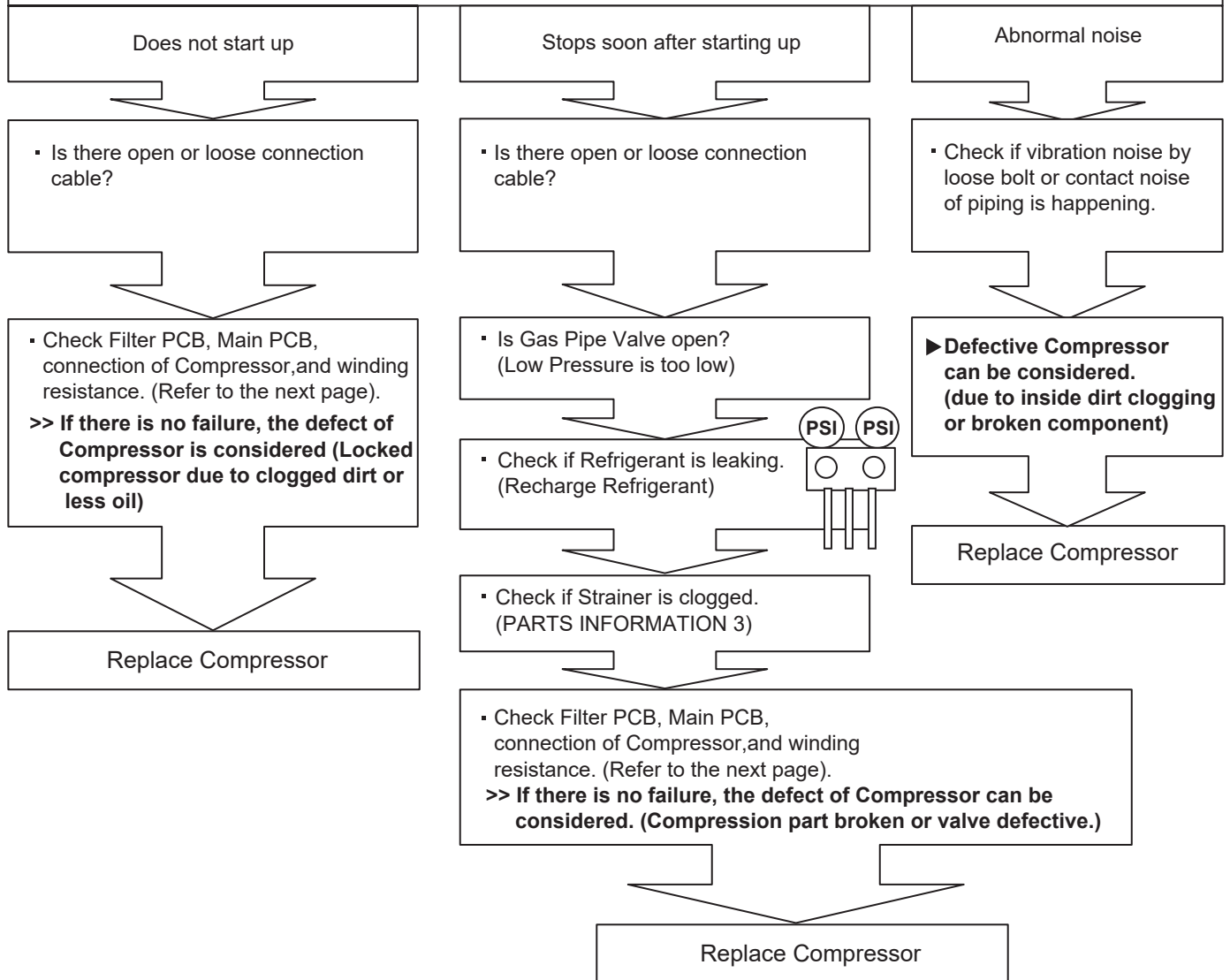

SERVICE PARTS INFORMATION 2

Compressor

Test 1 : Check Connection

- Check terminal connection of Compressor (loose or incorrect wiring)

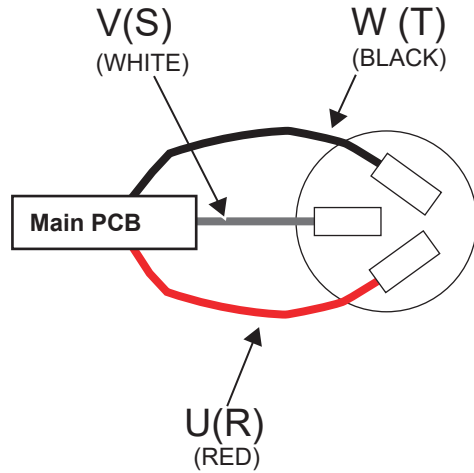

- Check terminal connection of Main PCB (loose or incorrect wiring)

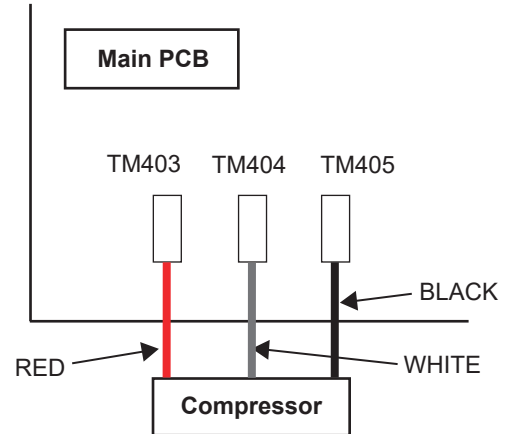

Test 2 : Check Winding Resistance

- Check winding resistance of each terminal

► **If the resistance value is 0Ω or infinite, replace Compressor.**

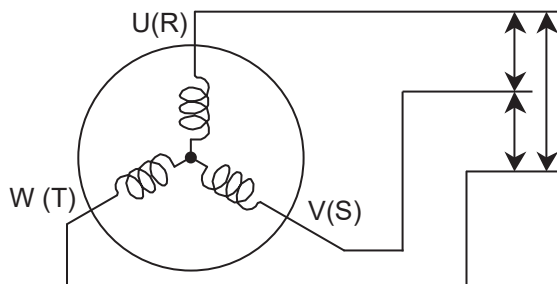

Resistance Value : $0.642\Omega \pm 8\%$ (68°F(20°C))

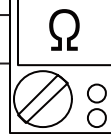

Test 3 : Replace Main PCB

► **If the symptom does not change with above Check 1, 2, replace Main PCB.**
(SERVICE PARTS INFORMATION 10)

SERVICE PARTS INFORMATION 3

Outdoor unit electronic expansion valve (EEV)

Test 1 : Check Connections

- Check connection of connector
(Loose connector or open cable)

For AOU36RLXFZH

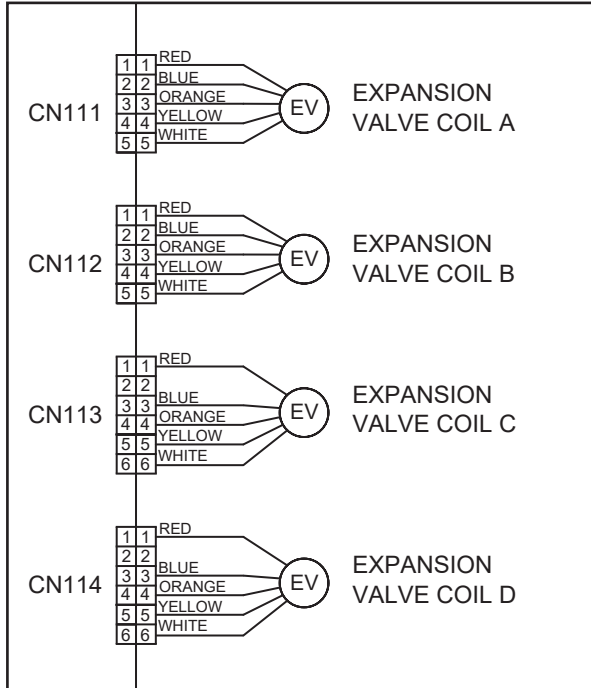

For AOU45RLXFZ

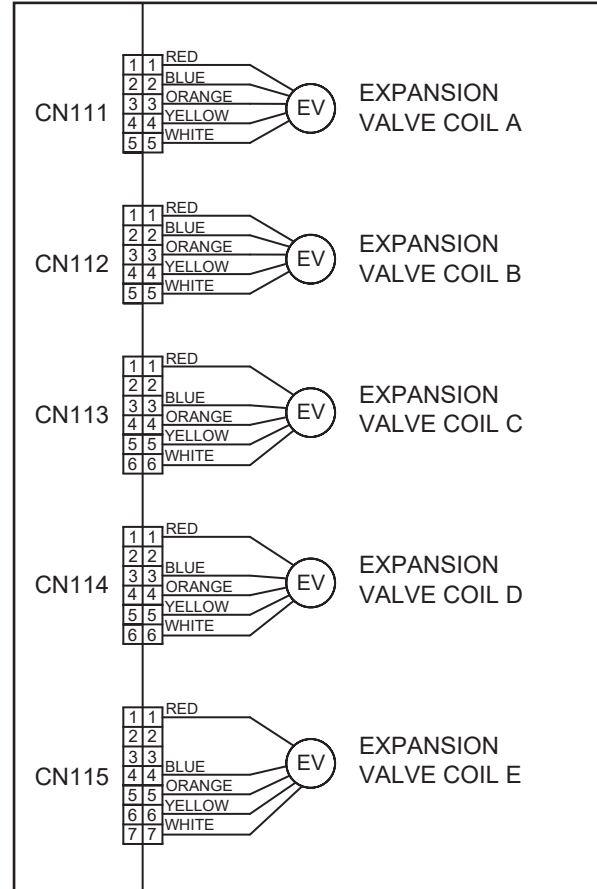

Test 2 : Check Coil of EEV

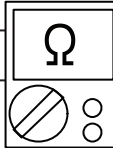

· Remove connector, check each winding resistance of Coil.

Read wire	Resistance value
White - Red	46 Ω ± 4 Ω at 68°F(20°C)
Yellow - Blue	
Orange - Red	
Blue - Orange	

▶ **If Resistance value is abnormal, replace EEV.**

Test 3 : Check Voltage from Main PCB.



· Remove Connector and check Voltage (DC12V)

▶ **If it does not appear, replace Main PCB.**

Test 4 : Check Noise at start up

· Turn on Power and check operation noise.

▶ **If an abnormal noise does not show, replace Main PCB.**
(SERVICE PARTS INFORMATION 10)

Test 5 : Check Opening and Closing Operation of Valve

When Valve is closed,
it has a temp. difference between Inlet and Outlet.

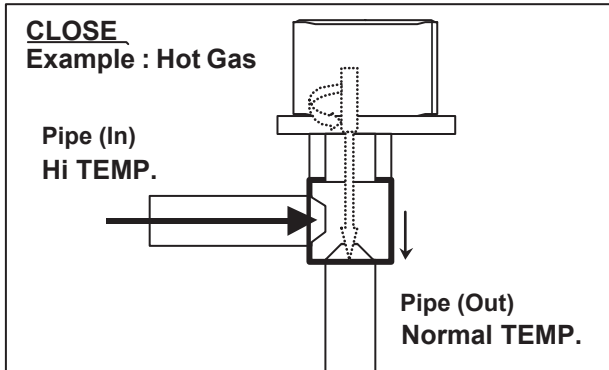

If it is open,
it has no temp. difference between Inlet and Outlet.

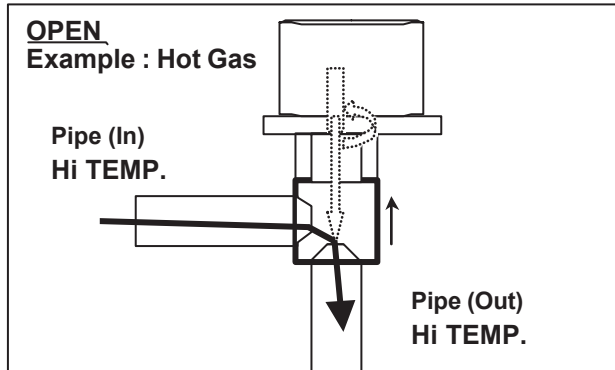

Test 6 : Check Strainer

Strainer normally does not have temperature difference between inlet and outlet as shown in ① ,
but if there is a difference as shown in ② , there is a possibility of inside clogged. In this case, replace Strainer.

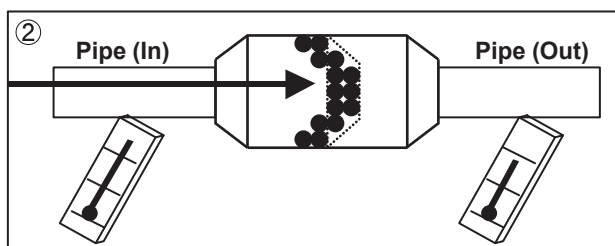
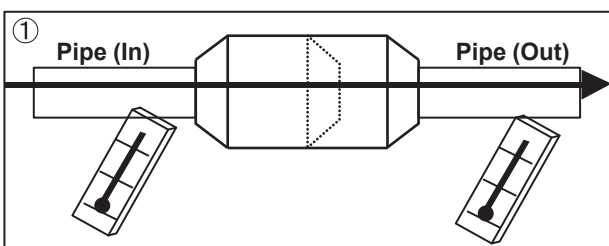

SERVICE PARTS INFORMATION 4

Discharge pressure sensor

Test 1 : Check the voltage from Main PCB

DC

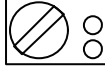

- With the connector connected to the Main PCB, measure the voltage between CN 92 : 2 - 3 of the Main PCB

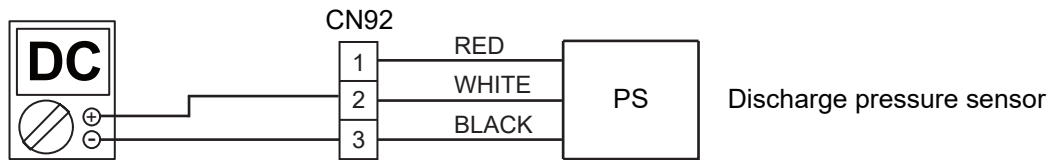

- Characteristics of pressure sensor

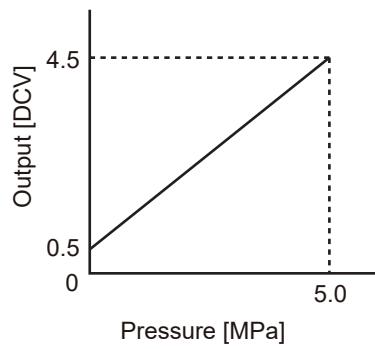

SERVICE PARTS INFORMATION 5

Indoor unit fan motor

Test 1 : Check rotation of Fan

- Rotate the fan by hand when operation is off.
(Check if fan is caught, dropped off or locked motor)
- >>If Fan or Bearing is abnormal, replace it.**

Test 2 : Check resistance of Indoor Fan Motor

- Refer to below. Circuit-test "Vm" and "GND" terminal.
(Vm: DC voltage, GND: Ground terminal)
- >>If they are short-circuited (below 300 kΩ), replace Indoor fan motor and Controller PCB.**

For Compact Wall Mount, Wall Mount Type

Pin number (wire color)	Terminal function (symbol)
1 (Blue)	Feed back (FG)
2 (Yellow)	Speed command (Vsp)
3 (White)	Control voltage (Vcc)
4 (Black)	Ground terminal (GND)
5	No function
6 (Red)	DC voltage (Vm)

For Floor Type

Pin number (wire color)	Terminal function (symbol)
1 (Blue)	Feed back (FG)
2 (Yellow)	Speed command (Vsp)
3 (White)	Control voltage (Vcc)
4 (Black)	Ground terminal (GND)
5	No function
6	No function
7 (Red)	DC voltage (Vm)

For Compact Cassette Type

Pin number (wire color)	Terminal function (symbol)
1 (Red)	DC voltage (Vm)
2	No function
3 (White)	Control voltage (Vcc)
4 (Black)	Ground terminal (GND)
5	No function
6	No function
7 (Yellow)	Speed command (Vsp)
8 (Brown)	Feed back (FG)

For Slim Duct Type

Pin number (wire color)	Terminal function (symbol)
1 (Blue)	Feed back (FG)
2 (Yellow)	Speed command (Vsp)
3 (White)	Control voltage (Vcc)
4 (Black)	Ground terminal (GND)
5	No function
6 (Red)	DC voltage (Vm)

SERVICE PARTS INFORMATION 6

Outdoor unit fan motor

Test 1 : Check rotation of Fan

- Rotate the fan by hand when operation is off.
(Check if fan is caught, dropped off or locked motor)
- >>If Fan or Bearing is abnormal, replace it.**

Test 2 : Check resistance of Outdoor Fan Motor

- Refer to below. Circuit-test "Vm" and "GND" terminal.
(Vm: DC voltage, GND: Ground terminal)
- >>If they are short-circuited (below 300 kΩ), replace Outdoor fan motor and Main PCB.
(SERVICE PARTS INFORMATION 10)**

Pin number (wire color)	Terminal function (symbol)
1 (Red)	DC voltage (Vm)
2	No function
3	No function
4 (Black)	Ground terminal (GND)
5 (White)	Control voltage (Vcc)
6 (Yellow)	Speed command (Vsp)
7 (Brown)	Feed back (FG)

For AOU36RLXFZH

SERVICE PARTS INFORMATION 7

Heater unit

Test 1 : Check Connections

- Check connection of connector
(Loose connector or open cable)

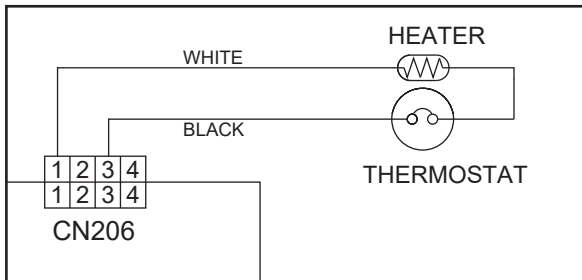

Test 2 : Check electrical components

- Check Check Fuses.
>> If Fuse is open, check connection, and replace Fuse.

Test 3 : Check Heater wire.

- Remove connector, check resistance of Heater wire.

Read wire	Resistance value
Black - White	320.7 - 367.3 Ω at 77°F (25°C)

- **If Resistance value is abnormal, replace Heater Unit.**

SERVICE PARTS INFORMATION 8

Active filter module

Test 1 : Check Open or Short-circuit and Diode (D1)

- Remove connector, check the open or short-circuit and the diode in the module

Check the open or short-circuit

Table.1 Each type standard value

Terminal		Resistance value	
		Type A	Type B
multimeter (+)	multimeter (-)	SACT32010 [HITACHI] LACT33020 [HITACHI]	PM-604 [FGEL] PM-703 [FGEL]
		PM-601 [FGEL] LOT No. - 1302931395	PM-601 [FGEL] LOT No. 1302931396 -
+ (+IN)*	- (-IN)*	360kΩ ± 20%	360kΩ ± 20%
- (-IN)*	N1 (N)*	0 Ω	0 Ω
※ P	+ (+IN)*	720kΩ ± 20%	900kΩ ± 20%
L1	L2	1.01MΩ / 0.76MΩ (Ref. value 1) (Ref. value 2)	1.01MΩ / 0.76MΩ (Ref. value 1) (Ref. value 2)
P	N1 (N)*	360kΩ ± 20%	540kΩ ± 20%
L1 , L2	Control Box	∞ Ω	∞ Ω
※ L2	N1 (N)*	1.65MΩ / 1.14MΩ (Ref. value 1) (Ref. value 2)	1.65MΩ / 1.14MΩ (Ref. value 1) (Ref. value 2)

* () is FGEL terminal name.

Table.2 Standard value is changed by the tool specification
(Type A and B are the same value)

Terminal		Resistance value
multimeter (+)	multimeter (-)	
※ L2	P	1.32MΩ / 0.66MΩ (Ref. value 1) (Ref. value 2)
※ P	L2	1.01MΩ / 0.76MΩ (Ref. value 1) (Ref. value 2)

※ By kind of multimeter , the value may change significantly.

Ref. value 1
Specifications for Multimeter
Manufacturer : FLUKE
Model name : FLUKE11
Power source : DC9V.

Ref. value 2
Specifications for Multimeter
Manufacturer : SANWA
Model name : PM3
Power source : DC3V.

► **If it is abnormal,replace ACTIVE FILTER MODULE**

LOT No. of PM-601 [FGEL] type

Label position

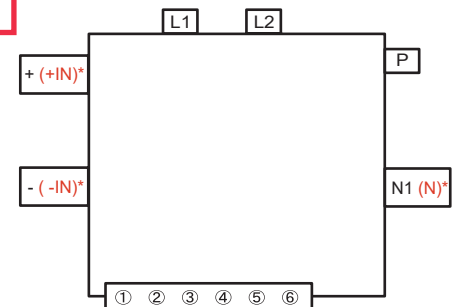
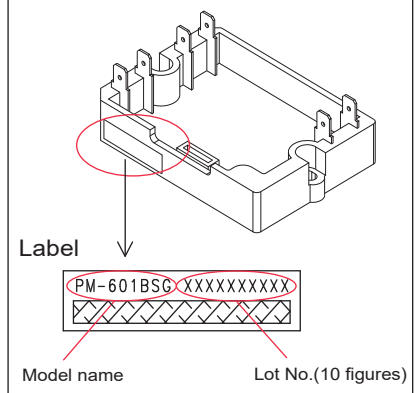

Test 2 : Check the Output DC voltage (between P and N)

- Check the Output DC voltage (between P and N) of compressor stopping and operating.

>> If the output voltage of compressor operating is less than the output voltage of compressor stopping,
Active Filter Module is defective. >> **Replace Active Filter Module**

SERVICE PARTS INFORMATION 9

IPM
(Mounted on Transistor PCB)

Test 1 : Check the Transistor of PCB (for Resistance)



- ① Disconnect the connection wires between the Transistor PCB - Capacitor PCB and Transistor PCB - Inverter Compressor.
- ② Set the tester to the "Resistance" mode, and measure the resistance between the following terminals.
 IC400-30 (P) - TM403(U) / TM404(V) / TM405(W)
 IC400-24 (N) - TM403(U) / TM404(V) / TM405(W)
- ③ Judge the result of ② as follows:

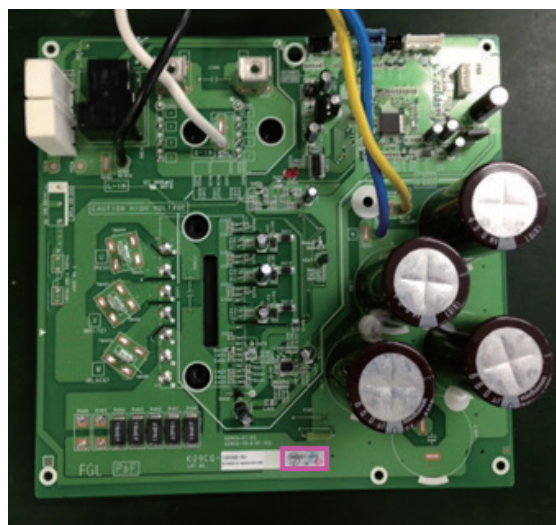

Terminal		Resistance value
Tester(+)	Tester(-)	
P	U	Over 2kΩ (Including ∞Ω)
P	V	
P	W	
U	P	Over 20kΩ (Including ∞Ω)
V	P	
W	P	
N	U	
N	V	Over 2kΩ (Including ∞Ω)
N	W	
U	N	
V	N	Over 2kΩ (Including ∞Ω)
W	N	

Test 2 : Check the Transistor of PCB (for Diode)

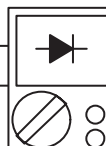

- ④ Set the tester to the "Diode" mode, and measure the voltage value between the following terminals.
- ⑤ Judge the result of ④ as follows:

Terminal		Tester display
Tester(+)	Tester(-)	
P	U	∞
P	V	
P	W	
U	P	0.3V ~ 0.7V
V	P	
W	P	
N	U	
N	V	∞
N	W	
U	N	
V	N	∞
W	N	

SERVICE PARTS INFORMATION 10

CAUTION of if the replace Main PCB(Outdoor unit)

CAUTION

If you are replace the Main PCB of the outdoor unit, please do the following things!
After the replaced Main PCB, normal operation is not possibility.

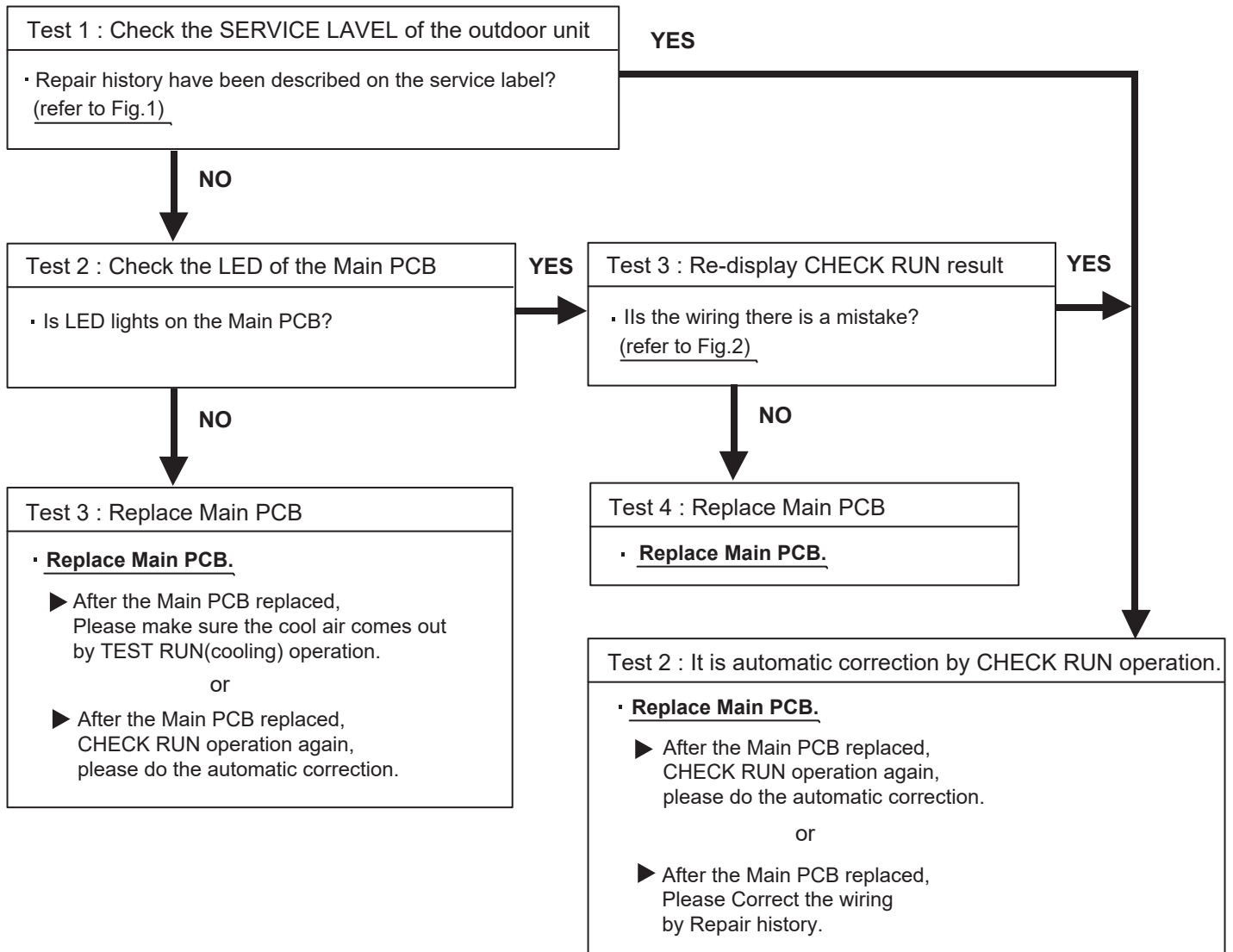

Example) when the 4 indoor units are connected

Fig.1 : SERVICE LEVEL

• Repair history (Ex.)

A	B	C	D	E	F
(A)	(C)	(B)	(D)	()	()

Reverse connection of Terminal B and Terminal C.

Fig.2 : Display of CHECK RUN operation

• Check results (Ex.)

POWER /MODE	ERROR	MONITOR					
		A	B	C	D	E	F

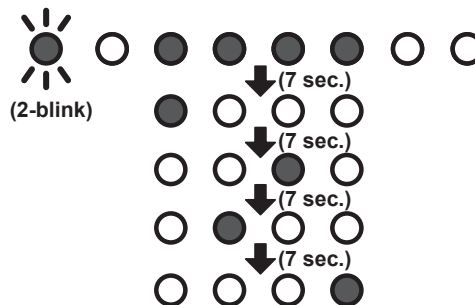

Reverse connection of Terminal B and Terminal C.



FUJITSU GENERAL LIMITED

3-3-17, Suenaga, Takatsu-ku, Kawasaki 213-8502, Japan